



SHREEYASH PRATISHTHAN'S



Shreeyash Technical Campus

SHREEYASH COLLEGE OF ENGINEERING & TECHNOLOGY,  
AURANGABAD

Date: 03/06/2022

## RISING RHYTHM-2022

### Cash Prize Distribution to Student for Different Activity

Sr.No.	Name of Event	Name of Student	1 <sup>st</sup> Prize	2 <sup>nd</sup> Prize
1	Dance	Mrunal Deshmukh (Civil)	300	
2		Payal Yadav (ETC)		200
3	Singing	Tejendra Kulkarni (CSE)	200	
4		Neha Zunje(Civil)	200	
5		Arvind Jadhav (Civil)		200
6	Drama	Dharmaveer Sambhaji Group	300	
7	Western Day	Rupali Hewade (CSE)	200	
8	Mismatch Day	Ravikant Akate (EE)	200	
9	Bachpan Day	Tukaram Padile (CSE)	200	
10	Filmy Day	Bhool Bhulaiyya Group	200	
11	Group Day	Gram Panchayat Group	200	
12	Halloween Day	Aniruddha Raut(CSE)	200	
13	Traditional Day	Tanaji Netke & Group	200	
14	Tapori Day	Netra Funde & Group	200	
15	Musical Chair	Ashwini Jadhav (Civil)	200	
16	Treasure Hunt	Gram Panchayat Group	200	

  
Cultural

In-Charge

  
Dr. R. S. Pawar

Principal



**Name of the event:** Annual Social Gathering-“Rising Rhythm-2022”

**Date of the event:** 30<sup>th</sup> May 2022 to 03<sup>rd</sup> June 2022

**Class:** All Classes

**Accompanying Staff:** A. B. Vawhale & Y. A .Kale

### Summary of the event:

The annual gathering and sports week was celebrated with enthusiasm. Various programs were organized on the theme “Transformation of India from Retro to Metro”. In Cultural programs such as Singing, Dancing, Dramas & Fashion show were held as well as various sports competitions were also organized such as Cricket, Volleyball, Kabaddi, Badminton, Chess, Carom, Running etc.

For the Inauguration ceremony Actor, Mr. India, Body builder All Asia 2015 champion **Mr.Sidhant More** was invited as a Chief Guest and Chairperson of the program Er. Basawaraj Mangrule was present. On that occasion College Principal Dr. R.S. Pawar, CEO Joy Daniel, Director Prabhakar Mashalakar, Student President Monali Chaudhar, Student Secretary Mansi Kulkarni, Head of the Department Prof. Smita Joshi, Prof. Jaiprakash Shastri, Prof. Vaibhav Chavan, Prof. Shaila Kharde, Prof. Kapil Patil, Prof. Anil Rokade and all teaching & non teaching faculty members.

There was a large participation of faculties & students in different activity like Western day, Mis-Match Day, Bachpan Day, Group Day, Halloween Day, Traditional Day, Tapani Day, and Filmy Day were celebrated.

Neha Zunje and Tejendra Kulkarni were awarded for the first prize in the singing competition and Arvind Jadhav was also awarded the second position. In dance competition, Mrunal Deshmukh came first position and Payal Yadav was awarded for the second position.

Shubham Chandane & Group was awarded first prize in the drama competition. The group included Shubham Chandane, Rahul Bansode, Rishika Awate, Shubham Kayande. They have presented an excellent play on the subject of Chhatrapati Sambhaji Raje.

Apart from cultural programs, various sports competitions were also organized. Cricket, volleyball, kabaddi, badminton, chess, carom, running, musical chair etc. competitions were organized in it. The Civil Engineering team won the first prize in cricket. The mechanical engineering team won first prize in volleyball and the computer engineering team won in kabaddi. Sanskar Wadodkar was given first prize in Badminton competition. Yogesh Rathod and Anmol Dhamone were given first prize in Chess and Carrom competitions respectively. Rituja Patil and Akash Hazare were awarded first prize in the women's and men's races respectively. Prizes were distributed to all the winning students at the hands of all the distinguished guests.

### Outcome:

- To exhibit student’s talent, remove their stage fear, boost up confidence and teach them teamwork.
- To bring out the enthusiasm in students and to make it an extraordinary talent.
- The most important thing is to make a decision about deciding the detail of the program such as what are the activities that will be included, students participating in the events, financial estimation of the program etc.
- To bring out the teachers, students, college management and parents on the same platform to conduct and have a good time together.

Photographs of the event:

Sports Activity

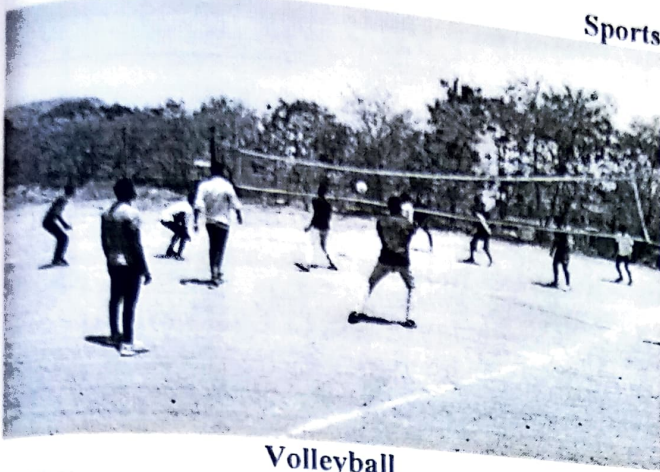

Volleyball



Kabbadi



Cricket



Running



Chess



Badminton

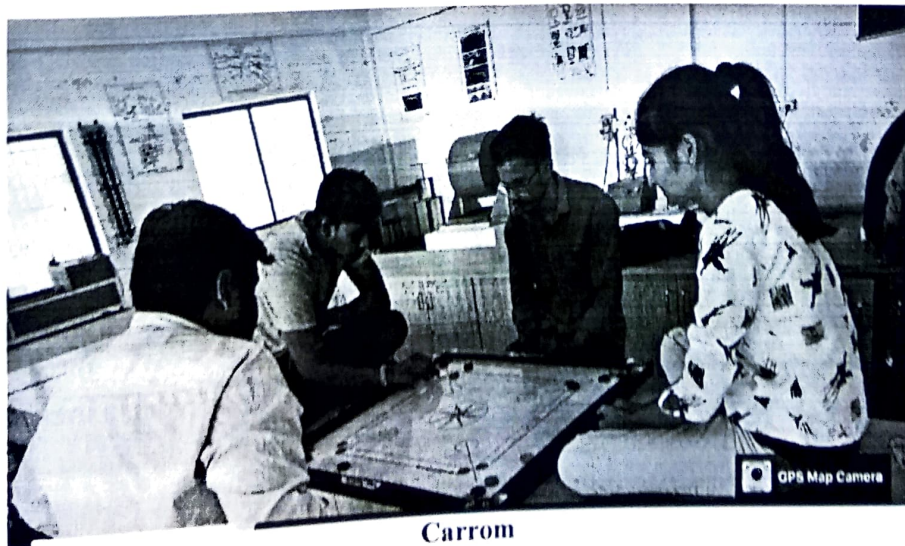

Carrom

Day's Celebration

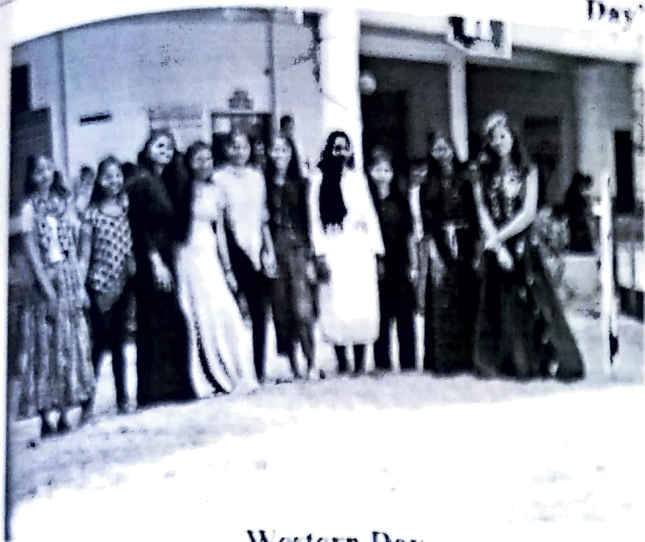

Western Day



Mismatch Day



Bachapan Day



Group Day



Filmy Day



Halloween Day



Traditional Day



Tapori Day

Cultural Event



Inauguration Ceremony



Student Council



Sport Prize Distribution



Activity Prize Distribution



Solo Dance Performance



Solo Singing Performance



Solo Dance Performance



Group Dance Performance



**Drama Performance**

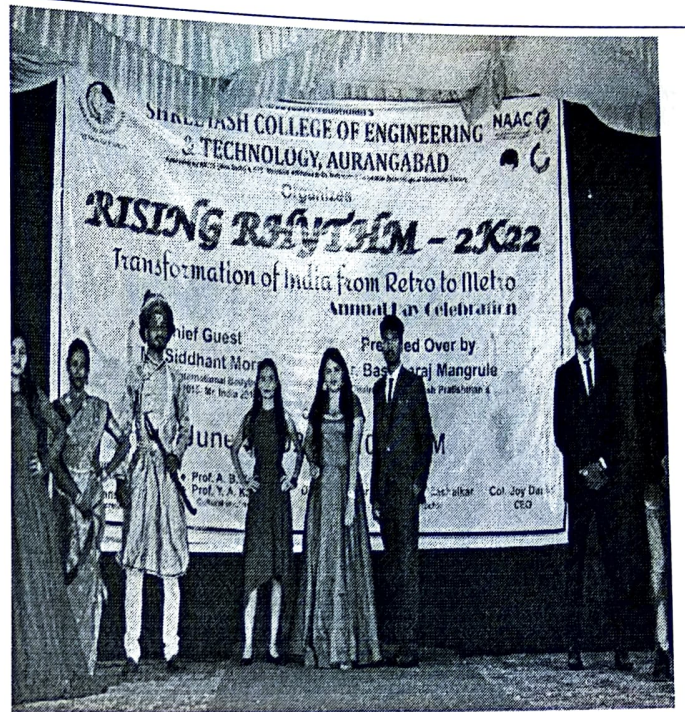

**Fashion Show**

*ABV*

**Prof. A.B.Vawhale & Prof.Y.A.Kale**  
Cultural Incharge

*[Handwritten Signature]*

**Dr. R. S. Pawar**  
Principal



# Shreeyash Pratishthan's

Shreeyash College of Engineering & Technology | MBA (DTE Code : 2112)  
Shreeyash Polytechnic (DTE Code : 2173)

Shreeyash Institute of Pharmacy (DTE Code : 2568)

Shreeyash Institute of Pharmaceutical Education & Research (DTE Code : 2572)  
Shreeyash College of Arts, Commerce & Science.



Ref. SYCET/Admin/2022/152

Date : 23/05/22

## STUDENT COUNCIL 2021-22

Sr. No.	Post	Name of Student	Class	Branch
1	President	Monali Chaudhar	BE	Civil
2	Secretary	Mansi Kulkarni	BE	Mechanical
3	Joint Secretary	Vaibhav Rathod	TE	Civil
4	Cultural Secretary	Goraksha Gorade	SE	Electrical
5	Joint Cultural Secretary	Komal Rathod	SE	CSE
6	Sport Secretary	Bhagwat Dhakne	TE	Mechanical
7	Joint Sport Secretary	Sanskar Wadodkar	SE	ETC
8	NCC In-Charge	Uday Rathod	FE	Mechanical
9	NSS In-Charge	Avinash Chavan	TE	Civil
10	Ladies Representative	Sakshi Kharchan	SE	CSE
11	Boys Hostel Representative	Mustak Shaikh	TE	Mechanical
12	Girls Hostel Representative	Sakshi Change	SE	CSE

PRINCIPAL

SYCET

Principal  
Shreeyash College of Engineering  
& Technology Aurangabad



Gut No. 258 (P), Near SRPF Camp, Satara Parisar, Aurangabad - 431 010.

Tel. No. (0240) 6608777 / 701 / 761 / 702. Tele / Fax : (0240) 6608709. www.syp.ac.in.





SHREEYASH PRATISHTHAN'S



## Shreeyash Technical Campus

SHREEYASH COLLEGE OF ENGINEERING & TECHNOLOGY,  
AURANGABAD

### RISING RHYTHM-2022

The following faculty members are informed that they are appointed as faculty advisor for respective committee for smooth conduction of annual gathering RISING RHYTHM-2022.

Sr.No.	Committee Name	Name of Faculty	Name of Student Coordinator	Faculty Signature
1	Cultural Incharge	Prof. A. B. Vawhale Prof. Y. A. Kale	President	
2	Main Program Stage Arrangement & Decoration Committee	Prof. Y.A. Kale (I/C) Prof. B. A. Shukla Prof. R. R. Galgali Prof. Kalyani Mane Prof. A. R. Sansare	Vaibhav Rathod Sakshi Kharchan	
3	Seating Arrangement Committee	Prof. V.W. Patil (I/C) Mr. T.D. Kanwate All Workshop Staff		
4	Discipline Committee	Prof. J. S. Shastri (I/C) Prof. S. P. Kharde Prof. A. H. Rokade Prof. K.T. Patil Prof. S. P. Kulkarni Prof. V. B. Chavan Prof. N. M. Deokar Prof. G. H. Dake Prof. A. N. Shaikh Prof. M. C. Shirsagar Prof. D. A. Deshmukh	Avinash Chavan Uday Rathod	
5	Felicitation Committee	Prof. G. N. Deshpande (I/C) Prof. Prof. S. P. Sharma Prof. K. M. Birare Prof. P. M. Marawar		
6	Anchoring Committee	Prof. A. E. Palve(I/C) Prof. Neha Quadri Prof. Masarrat Sultana	Mansi Kulkarni	
7	Singing Committee	Prof. A. B. Vawale(I/C) Prof. R.V. Rajvaidya Prof. M. C. Shirsagar	Tejandra Kulkarni Neha Zunje	
8	Dance Committee	Prof. S. S. Sonone (I/C) Prof. K.M. Birare Prof. S. S. Mandwale	Abhijit Shendre Vaishnavi Patil	
9	Drama Committee	Prof. S. S. Gadekar (I/C) Prof. Rubina Shah Prof. P. S. Jadhavar	Tanaji Netke Pooja Narote	
10	Fashion Show Committee	Prof. V. H. Nimbhore(I/C) Prof. S. P. Sharma	Atharv Gade Bhagyashri	



SHREEYASH PRATISHTHAN'S

Shreeyash Technical Campus



**SHREEYASH COLLEGE OF ENGINEERING & TECHNOLOGY,  
AURANGABAD**

11	Days Committee	Prof. Kalyani Mane Prof. Rubina Shah	Katkamwar	
		Prof. B. A. Shukla(I/C) Prof. A. D. Ghuge Prof. R. R. Kulkarni Prof. S. S. Shringarputale Prof. S. B. Banage	Goraksha Gorade Komal Rathod	
12	Sports Committee	Prof. M. M. Hanumanth(I/C) Prof. A. D. Lahane Prof. M.C. Kshirsagar Prof. D. A. Deshmukh Prof. S. S. Rathod Dr. H. A. Khawal Prof. H. Ambhore	Bhagwat Dhakne Sanskar Wadodkar	
13	Sponsorship Committee	Dr. H. A. Tonday(I/C) Prof. K. T. Patil Prof. R. H. Nimbhore	Shubham Jadhav	
14	Flash Mob Committee	Prof. M.C. Kshirsagar(I/C) Prof. P. N. Marawar	Abhijit Shendre Vaishnavi Patil	
15	Activity Committee	Prof. A. S. Pingale Prof. Z. A. Shaikh	Ganesh Dawkare Netra Funde	
16	Fish Pond Committee	Prof. U. S. Mankare(I/C) Prof. S. K. Pratapure		
17	Food Committee	Prof. A. H. Rokade Mr. Ganesh Lihinar Mr. T. D. Kanwate Mr. S. Y. Sonowane		
18	Photography Committee	Prof. A. D. Lahane(I/C) Mr. Parmeshwar Mhaske		
19	Rangoli Committee	Prof. P. N. Marawar(I/C) Prof. U. S. Mankare	Pooja Narote	
20	Certificate Committee	Prof. Saad Siddiqui(I/C) Prof. D. P. Khade Prof. S. P. Sharma		
21	Publicity Committee	Prof. H. B. Chothe(I/C) Prof. H. A. Tonday		
22	Invitation & Online Committee	Prof. A. E. Palve(I/C) Prof. R. R. Kulkarni		

*Yash*  
*Pr*  
Cultural

Dr. R. S. Pawar

Principal



SHREEYASH PRATISHTHAN'S

Shreeyash Technical Campus



SHREEYASH COLLEGE OF ENGINEERING & TECHNOLOGY,  
AURANGABAD

RISING RHYTHM-2022

The following faculty members are informed that they are appointed as faculty advisor for respective committee for smooth conduction of annual gathering RISING RHYTHM-2022.

Sr.No.	Committee Name	Name of Faculty	Name of Student Coordinator	Faculty Signature
1	Cultural Incharge	Prof. A. B. Vawhale Prof. Y. A. Kale	President	<i>Y. A. Kale</i>
2	Main Program Stage Arrangement & Decoration Committee	Prof. Y.A. Kale (I/C) Prof. B. A. Shukla Prof. R. R. Galgali Prof. Kalyani Mane Prof. A. R. Sansare.		<i>Balaji, Kalyani, Balaji, Sansare</i>
3	Seating Arrangement Committee	Prof. V.W. Patil (I/C) Mr. T.D. Kanwate All Workshop Staff		<i>V. W. Patil</i>
4	Discipline Committee	Prof. J. S. Shastri (I/C) Prof. S. P. Kharde Prof. A. H. Rokade Prof. K.T. Patil Prof. S. P. Kulkarni Prof. V. B. Chavan Prof. N. M. Deokar Prof. G. H. Dake Prof. A. N. Shaikh Prof. M. C. Shirsagar Prof. D. A. Deshmukh.		<i>J. S. Shastri, S. P. Kharde, A. H. Rokade, K.T. Patil, S. P. Kulkarni, V. B. Chavan, N. M. Deokar, G. H. Dake, A. N. Shaikh, M. C. Shirsagar, D. A. Deshmukh.</i>
5	Felicitation Committee	Prof. G. N. Deshpande (I/C) Prof. Prof. S. P. Sharma Prof. K. M. Birare Prof. P. N. Marawar		<i>G. N. Deshpande, S. P. Sharma, K. M. Birare, P. N. Marawar</i>
6	Anchoring Committee	Prof. A. E. Palve(I/C) Prof. Neha Quadri Prof. Masarrat Sultana		<i>A. E. Palve, Neha Quadri, Masarrat Sultana</i>
7	Singing Committee	Prof. A. B. Vawale(I/C) Prof. R.V. Rajvaidya Prof. M. C. Shirsagar	Dr. H.A. Tonday	<i>A. B. Vawale, R.V. Rajvaidya, M. C. Shirsagar</i>
8	Dance Committee	Prof. S. S. Sonone (I/C) Prof. K.M. Birare Prof. S. S. Mandwale		<i>S. S. Sonone, K.M. Birare, S. S. Mandwale</i>
9	Drama Committee	Prof. S. S. Gadekar (I/C) Prof. Rubina Shah Prof. P. S. Jadhavar		<i>S. S. Gadekar, Rubina Shah, P. S. Jadhavar</i>



SHREEYASH PRATISHTHAN'S  
Shreeyash Technical Campus



SHREEYASH COLLEGE OF ENGINEERING & TECHNOLOGY,  
AURANGABAD

10	Fashion Show Committee	Prof. V. H. Nimbhore(I/C) Prof. S. P. Sharma Prof. Kalyani Mane Prof. Rubina Shah	
11	Days Committee	Prof. B. A. Shukla(I/C) Prof. A. D. Ghuge Prof. R. R. Kulkarni Prof. S. S. Shringarputale Prof. S. B. Banage	
12	Sports Committee	Prof. M. M. Hanumanth(I/C) Prof. A. D. Lahane Prof. M.C. Shirsagar Prof. D. A. Deshmukh Prof. S. S. Rathod Dr. H. A. Khawal Prof. H. Ambhore	
13	Fish Pond Committee	Prof. U. S. Mankare(I/C) Prof. S. K. Pratapure	 10/05/2022
14	Food Committee	Prof. A. H. Rokade Mr. Ganesh Lihinar Mr. T. D. Kanwate Mr. S. Y. Sonowane	
15	Photography Committee	Prof. A. D. Lahane(I/C) Mr. Parmeshwar Mhaske	
16	Rangoli Committee	Prof. P. N. Marawar(I/C) Prof. U. S. Mankare	 20/05/2022
17	Certificate Committee	Prof. Saad Siddiqui(I/C) Prof. D. P. Khade Prof. S. P. Sharma	
18	Publicity Committee	Prof. H. B. Chothe(I/C) Prof. H. A. Tonday	
19	Invitation & Online Committee	Prof. A. E. Palve(I/C) Prof. R. R. Kulkarni	

Cultural  
In-Charge

Dr. R. S. Pawar  
Principal

Date: 20/05/2022

## NOTICE

### RISING RHYTHM 2022

All the students and faculty members are here by informed that we are going to organize **Annual Social Gathering Rising Rhythm-2022** from 23/05/2022 to 31/05/2022. So all are invited to participate in sports and cultural activities and detail schedule of activities announced will soon.

  
Cultural In-Charge

Prof. A. B. Vawhale

Prof. Y.A. Kale







  
Sports In-Charge

Prof. M. M. Hanumante

  
Principal

Dr.R.S.Pawar

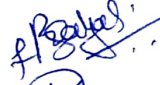
SYCET

EE -   
Engg. Scie. -   
MBA - For   
E&TC -   
CSE -   
Mech -   
Civil - 

## NOTICE

All the Divisional Representatives (DR/CR) of all the classes of all branches are informed that as per the statutes of Dr.B.A.T.University Lonere following are the various designations /posts which are mandatory for the formation of the **Student Council**, so there is a meeting for the following post on **21/05/2022** dated at **1.00 PM** in **Hall No. ~~102~~ / 228**

1. President
2. Secretary
3. In-charge Cultural Activity
4. In-charge Sport
5. In-charge NCC
6. In-charge NSS
7. Ladies Representative
8. Boys Hostel Representative
9. Girls Hostel Representative
10. SC/ST/NT/OBC Representative

  
Principal  
SYCET



Date: 20/05/2022

Departmental Cultural In-Charge

(Cultural Club)

Sr.No	Name of Staff Member	Branch	Designation
1.	Prof. A. B. Vawale	CIVIL	In-charge
2.	Prof. Y. A. Kale	EE	In-charge
3.	Prof. B.A. Shukla	MECH	Co-ordinator
4.	Prof. Rahul Nagte	MECH	Co-ordinator
5.	Prof. R. R. Kulkarni	EE	Co-ordinator
6.	Prof. V. H. Nimbhore	CIVIL	Co-ordinator
7.	Prof. M. C. Shirsagar	CSE	Co-ordinator
8.	Prof. S. A. Pandav	FE ENGG	Co-ordinator
9.	Prof. S. S. Sonone	ETC	Co-ordinator
10.	Prof. Saad Siddiqui	MBA	Co-ordinator

Above staff members are appointed for smooth conduction of Cultural activity.

  
Cultural

In-charge

  
Principal

SYCET



SHREEYASH PRATISHTHAN'S

Shreeyash Technical Campus

SHREEYASH COLLEGE OF ENGINEERING & TECHNOLOGY,  
SHREEYASH POLYTECHNIC,  
SHREEYASH INSTITUTE OF PHARMACY,  
SHREEYASH INSTITUTE OF PHARMACEUTICAL EDUCATION AND RESEARCH



Date: 25/02/2022

## NOTICE

All the students are informed that as per the Statutes of Dr. Babasaheb Ambedkar Technological University, Lonere, every affiliated institute is required to form "Students' Council".

Following are the various designation / posts which are mandatory for the formation of the council.

1. President
2. Secretary
3. In-charge Cultural Activities
4. In-charge Sports
5. In-charge NCC — Udg. Rth. d
6. In-charge NSS — ~~Udg. Rth. d~~ Anash chavan
7. Ladies Representative
8. Boys' Hostel Representative
9. Girls' Hostel Representative
10. SC/ST/NT/OBC Representative

For the above posts, desired students are required to submit handwritten application along with supporting evidences strengthening their candidature on or before 10 March 2022

Principal  
Dr. R. S. Pawar





SHREEYASH PRATISHTHAN'S

## Shreeyash Technical Campus

SHREEYASH COLLEGE OF ENGINEERING & TECHNOLOGY,  
SHREEYASH POLYTECHNIC,  
SHREEYASH INSTITUTE OF PHARMACY,  
SHREEYASH INSTITUTE OF PHARMACEUTICAL EDUCATION AND RESEARCH



### Criteria and Responsibilities:-

#### A. President

1. The candidate must be meritorious and he/she should not have any backlog throughout the academic year.
2. The candidate must be a regular student of the Institute.
3. The candidate should be versatile i.e. he / she should participate in different activities
4. The candidate shall not have a previous criminal record.
5. The candidate shall not have been subject to any disciplinary action by the Institute or authorities.
6. The candidate should not have any dues to Institute and Hostels.
7. The candidate should have attained the minimum percentage of attendance as prescribed by the university or 75% attendance, whichever is higher.

#### Responsibilities:

1. Provides direction for monthly meetings.
2. Provides introductory materials for new members.
3. Serves as primary facilitator for Council meetings.
4. Oversees all activities within the council, provides ideas and is particularly attentive to how the council is run and the process improved continually.
5. Duties also include managing funds and keeping the council updated on the status of monetary resources.
6. Suggesting the administration to improve the student amenities to improve their career and personality building.
7. Helping the administration in smooth conduct of student activities on the campus.
8. Guiding the junior and needy students to improve their technical, organizational and managerial skills by organizing seminars/ symposia/ workshops etc.
9. Encouraging innovative and creative skills of the under graduate and post graduate students.

#### B. Secretary

1. The candidate must be meritorious and he/she should not have any backlog throughout the academic year.
2. The candidate must be a regular student of the Institute.
3. The candidate should be versatile i.e. he / she should participate in different activities
4. The candidate shall not have a previous criminal record.
5. The candidate shall not have been subject to any disciplinary action by the Institute or authorities.
6. The candidate should not have any dues to Institute and Hostels.
7. The candidate should have attained the minimum percentage of attendance as prescribed by the university or 75% attendance, whichever is higher.



SHREEYASH PRATISHTHAN'S

Shreeyash Technical Campus

SHREEYASH COLLEGE OF ENGINEERING & TECHNOLOGY,  
SHREEYASH POLYTECHNIC,  
SHREEYASH INSTITUTE OF PHARMACY,  
SHREEYASH INSTITUTE OF PHARMACEUTICAL EDUCATION AND RESEARCH



### **Responsibilities:**

1. Duties include careful note taking of every meeting and sending minutes to email list
2. Duties also include keeping attendance, keeping track of which bodies are represented, and working with representative groups to ensure participation
3. The Secretary creates and organizes the distribution of all documents pertaining to student council at institution and university level
4. Prevention of ragging in the campus through counseling senior students, helping the administration whenever necessary.
5. Suggesting the administration to improve the student amenities to improve their career and personality building.
6. Helping the administration in smooth conduct of student activities on the campus.
7. Guiding the junior and needy students to improve their technical, organizational and managerial skills by organizing seminars/ symposia/ workshops etc.
8. Encouraging innovative and creative skills of the under graduate and post graduate students.

### **C. In-charge Cultural Activities**

1. The candidate must be meritorious and he/she should not have any backlog throughout the academic year.
2. The candidate must be a regular student of the Institute.
3. The candidate should be versatile i.e. he / she should participate in different activities
4. The candidate shall not have a previous criminal record.
5. The candidate shall not have been subject to any disciplinary action by the Institute or authorities.
6. The candidate should not have any dues to Institute and Hostels.
7. The candidate should have attained the minimum percentage of attendance as prescribed by the university or 75% attendance, whichever is higher.

### **Responsibilities:**

1. Prevention of ragging in the campus through counseling senior students, helping the administration whenever necessary.
2. Suggesting the administration to improve the student amenities to improve their career and personality building.
3. Helping the administration in smooth conduct of student activities on the campus.
4. Guiding the junior and needy students to improve their technical, organizational and managerial skills by organizing seminars/ symposia/ workshops etc.
5. Encouraging innovative and creative skills of the under graduate and post graduate students.

## Department of Mechanical Engineering

### List of Class Representatives (CRs)

Academic Year 2021-22

Sr. No.	Name of the Student	Class	Contact No.	Email ID	CGPA
1.	Apparao Pawar	SE-A	8329801128	apparaopawar7@gmail.com	7.17
2.	Harish Tukaram Jagtap	SE-B	8459705492	harishjagtap332@gmail.com	DSY
3	Mohd Asraruddin	SE-C	8888462565	mohdasararuddin707@gmail.com	DSY
4.	Shaikh Mustak Rasul	TE-A	9146090502	mustakshaikh2101@gmail.com	8.7
5.	Juye Pratik Arjun	TE-B	7757880554	pratika.juye@gmail.com	9.65
6.	Kulkarni Mansi Sunil	BE-A	7218270099	mansikulkarni2357@gmail.com	9.41
7.	Futwaik Neha Devidas	BE-B	7741942543	nehafutwaik9720@gmail.com	9.21

  
09/05/22  
H.O.D.

  
Principal

Shreeyash Pratishtan's

## Shreeyash College of Engineering & Technology

Satara Parisar, Beed By-Pass Road, Aurangabad - 431 010 (M.S.)

T: +91 240 6608784 / 702, F: +91 240 6608709, E: principal@sycet.org, Web: www.sycet.org & [www.syp.ac.in](http://www.syp.ac.in)

Department: Civil Engineering

Academic Year : 2021-2022

Sr.No.	Name of Student	Year	Contact Number
01	Chaudhar Monali	B-tech	7218013674
02	Mohit Aarya	B-tech	7058444480
03	Lomate Sujit	TE	9373056105
04	Rathod Vaibhav	TE	7038882473
05	Pooja Narote	SE	8554998853
06	Dyaneshwar Fuke	SE	7620739917

Shreeyash college of Engineering and Technology

Electrical Engineering Department

Academic Year 2021-22

Sr.No	Name of the student	Class with Division	Contact Number
1	KAKDE ASHWINI	B. Tech	9307647685
2	KULKARNI UDAY	B. Tech	8668389848
3	RAJPUT VRUSHALI PRAVIN	TE	7038303094
4	LAHANE VAISHNAVI	TE	9284088018
5	Gorade Goraksh	SE	9022079109
6	Phuke Bhagyashri	SE	7083304791



SHREEYASH PRATISHTHAN'S  
SHREEYASH COLLEGE OF ENGINEERING & TECHNOLOGY, AURANGABAD  
Satara Parisar, Beed By-Pass Road, Aurangabad -431010 (M.S.)



NAAC Accredited, ISO Certified Institute  
(Approved by AICTE, DTE & Govt. of Maharashtra, Affiliated to Dr. B.A.T. University, Lonere)  
Gut No. 258 (P), Satara Parisar, Tq. Dist. Aurangabad  
Web : [www.syp.ac.in](http://www.syp.ac.in), Email : [sycet@yahoo.com](mailto:sycet@yahoo.com), Ph. (0240) 6608701/702/710

Date: 12 / 04 / 2022

Following is the list of CRs of their respective classes of Computer Science and Engineering Department as required for the Student Council.

Sr.No.	Name of Student	Class with Division	Contact Number
1	Mahajan Avinash D.	BE (CSE)	7767876692
2	Chavan Sanket R.	TE (CSE)	8983353581
3	Tejendra Kulkarni	SE (CSE)	9421257504

Sakshi Pharochhe SE  
Swami Navnath TE

HOD

CSE

SHREEYASH PRATISHTHAN'S  
**Shreeyash Technical Campus**  
 (SHREEYASH COLLEGE OF ENGINEERING & TECHNOLOGY,  
 SHREEYASH POLYTECHNIC)

**LIST OF CLASS REPRESENTATIVES (CR)**

Academic Year: 2021-22

Sr. No.	Name Of The Student	Class	Contact Number	Email ID	Passing Percentage/ CGPA
1	Patil Anurag Dnyaneshwar	SE	8485043926	anuragdp2002@gmail.com	89.12
2	Pophale Pavan Sudhakar	TE	7558467627	pophalepavan@gmail.com	CGPA-9.55
3	Lachuriye Shubham Omprakash	BE	7721998146	shubhamlachuriye@gmail.com	CGPA-9.06

*Sanskar Wadolkar SE*

*Wadolkar*  
HOD

*Wadolkar*  
PRINCIPAL



SHREEYASH PRATISHTHAN'S

SHREEYASH COLLEGE OF ENGINEERING & TECHNOLOGY, AURANGABAD

Satara Parisar, Beed By-Pass Road, Aurangabad -431010 (M.S.)

NAAC Accredited, ISO Certified Institute



(Approved by AICTE, DTE & Govt. of Maharashtra, Affiliated to Dr. B.A.T. University, Lonere)

Gut No. 258 (P), Satara Parisar, Tq. Dist. Aurangabad

Web : www.syp.ac.in, Email : sycet@yahoo.com, Ph. (0240) 6608701/702/710

Date: 09 / 04 / 2022

All the HODs are informed to provide the list of CRs of their respective classes in following format to undersigned on or before 12<sup>th</sup> April 2022. It is required to form the Student Council.





Sr.No.	Name of Student	Class with Division	Contact Number

  
Principal

soft-copy sent by Email

Copy to:

- 1) All Hods

fs — Syed  
 mech —   
 civil —   
 GC —   
 CSE —   
 BTC — 



Shreeyash College of Engineering and Technology, Aurangabad

Date: 04/06/2022

RISING RHYTHM 2022

Expenditure occurred for Guest Felicitation

Sr. No.	Name of Item	Quantity	Balance	Cost
1	Shivaji Maharaj Statue	1	0	1200
2	Printing of College Name	1	0	100
3	Shawal [Cotton goods]	2	1	360
4	Petrol for Traveling to city	1	0	100
5	Samai Decoration Flowers Yellow	2	0	80
6	Samai Decoration Flowers Pink	1	0	50
7	Bouquet	2	0	260
8	Red Roses	30	0	90
9	<b>Total Expenditure</b>			<b>2240</b>

  
Felicitation I/C



# SHREYASH PRATISHTHAN'S Sheeyash College of Engineering & Technology, Aurangabad



(An ISO 9001: 2008 ISO 14001: EMS & ISO 18001: 2007 OHSAS, Certified Institute)

Approved by: AICTE, New Delhi. Recognized by: Govt. of Maharashtra & DTE, Mumbai

Affiliated to: Dr. Babasaheb Ambedkar Marathwada University Aurangabad.  
Phone No. (0240) 6608701/702/709

Date: 21/05/2022

## Notice

All the students and staff members are here by informed that we are going to organize annual sports activities from 23<sup>rd</sup> to 30<sup>th</sup> May 2022. So all are invited to participate in below mentioned Sports activities:

So we are going to arrange inauguration ceremony held on 24<sup>th</sup> May 2022 at 10:00 AM on Cricket Ground.

Sr. No	Name of Sports	Entry Fees	Participants	Sports Coordinator	Contact No
1	Volleyball	200/-	Students & Staff	Mr.Umesh Changulpaye Mr.Vaibhav Rathod	8055393133 9307250877
2	Football	200/-	Students	Mr.Umesh Changulpaye	8055393133
3	Cricket	400/-	Students & Staff	Mr.Dhakane Bhagwat Mr.Sanskar Wadodkar Mr.Akshay Sarode	7083749166 7798081480 9112139598
4	Box Cricket	200/-	Students & Staff	Mr.Sanskar Wadodkar	7798081480
5	Badminton	100/-	Students & Staff	Mr.Sanskar wadodkar	7798081480
5	Kabaddi	150/-	Students	Mr.Dhakane Bhagwat Mr.Akash Bankar	8766530790 9011503137
7	Long Jump	30/-	Students	Mr. Akash Hajare	8308529843
8	Running (100M)	30/-	Students	Mr.Avinash Chavan	9373149355
	Carom	100/-	Students	Mr.Vishal Deshmukh	9975782146
9	Chess	100/-	Students	Mr.Vivek Gathude	9689718868

Prof. M.M.Hanmanthe  
Sports In charge SYCET

Dr. R. S. Pawar  
Principal SYCET

## Staff Cricket & Volleyball Team

(Mech, CSE & MBA)

Following faculty's team is formed for playing Cricket & Volleyball Games

1. Dr. R. S. Pawar
2. Prof. A. H. Rokade ( Captain)
3. Prof. K. T. Patil
4. Dr. Hulas Tonday
5. Prof. D. A. Deshmukh
6. Prof. M. C. Ksirsagar
7. Prof. G.S. Wayal
8. Prof. G.N. Deshpande
9. Prof. Harshal Chothe
10. Prof. Anil Palve
11. Prof. I. S. Shiddiqui
12. Prof. A. V. Kodarkar
13. Prof. S. A Shimple
14. Prof. A. N. Shastri

Note:- Some faculty's are in Reserve



**Dr. R. S. Pawar**  
Principal



SHREEYASH PRATISHTHAN'S

## Shreeyash Technical Campus

(SHREEYASH COLLEGE OF ENGINEERING & TECHNOLOGY)



RISING RHYTHM-2022

### Sports Prize Distribution Ceremony

Sr. No	Name of Game	Runner-up Team	Winner Team
1	Cricket	1. Rohan Ashok Kulkarni(MECH) 2. Bhagwat Ashok Dhakane 3. Sudarshan Pujaram Chaudari 4. Musthak Rasul Shaikh 5. Navnath Vishnu Shinde 6. Shubham Sainath Dhas 7. Abhishek Sanjay Kharat 8. Pratik Arjun Juye 9. Navnath Madhukar Salve 10. Ajim Majid Shaikh 11. Rushikesh Madan Jadhav 12. Shubham Narayan Gawande 13. Kartik Dharasingh Pawar 14. Nikhil Ravindra Kulkarni 15. Nikhil Dadarao Shahane	1. Dnyaneshwar Parasram Chavan 2. Ajay Raju Chavan(CIVIL) 3. Avinash Devichand Chavan 4. Vaibhav Bhimrao Rathod 5. Sajid Majid Shaikh 6. Niranjan Gokul Chavan 7. Abhijit Yadav Shendre 8. Rohidas Kakade 9. Avinash Misal 10. Sameer Pathan 11. Bharat Sukhdev Chaudhary 12. Prabuddha Manik Waghmare 13. Sujit Bhagwat Laute 14. Rohit Vilasrao Shinde 15. Satish Bihade
2	Vollyball	1. Ajay Ramdas Rathod(ELECTRICAL) 2. Akshay Gopal Sarode 3. Shubham Shankar Makode 4. Ravikant Sanjay Akate 5. Akash Bhaskar Kakde 6. Jagdish Ankush Taur 7. Rajesh Mansingh Rathod 8. Sushant Bhagwat Waghmare 9. Rushikesh Baban Pathade 10. Shivraj Vishnu Tangade	1. Sudarshan Pujaram Chaudari(MECH) 2. Shubham Narayan Gawande 3. Navnath Vishnu Shinde 4. Bhagwat Ashok Dhakane 5. Musthak Rasul Shaikh 6. Rohan Ashok Kulkarni 7. Rushikesh Madan Jadhav 8. Pratik Arjun Juye 9. Nikhil Ravindra Kulkarni 10. Aniket Madan Jadhav
3	kabaddi	1. Ashutosh Ganesh Sodnar(AASTHA) 2. Yash Sanjay Bhosale 3. Atharv Rajendra Shelke 4. Pratik Balwant Bojage 5. Karan Govind Pathade	1. Akash Bankar(CSE) 2. Akash Suresh Hajare 3. Omkar Appasaheb Hapase 4. Aditya Narayan Sangule 5. Bharat Chaudari



SHREEYASH PRATISHTHAN'S

## Shreeyash Technical Campus

(SHREEYASH COLLEGE OF ENGINEERING & TECHNOLOGY)



		6.Ajay Dhondiram Kakade 7.Tejas Sanjay Pawar 8.Kartik Manikrao Tale 9.Aary Ramesh Patil	6.Sachin Dake 7.Roshan Rathod
4	Badminton Single (Girls)	NIKITA PATIL	VAISHNAVI PIMPLE
5	Badminton Single (Boys)	ANMOL DHAMON	SANSKAR MAKARAND WADODKAR
6	Chess	SANKET SONAWANE(FE)	YOGESH RATHOD(EE)
7	Carrom Double	1.BADAL MANE 2.PRABUDHA WAGHMARE	1.ANMOL DHAMON 2.TANAJI NETKE
8	Running (100m) Girls	Ashwini.A.Jadhav	Rutuja A.Patil
9	Running (200m) Girls	Ashwini.A.Jadhav	Rutuja A.Patil
10	Running (100m) Boys	1.Babasaheb Zalte 2.Ishwar Dighule	Akash Hajare
11	Running (200m) Boys	1.Babasaheb Zalte 2.Ishwar Dighule	Akash Hajare

  
Bhagwat Dhakane

**Sports Secretary**

  
M.M.Hanmanth

**Sports In charge**

  
Dr. R.S.Pawar

**Principal**

Shreeyash college of Engineering and Technology Aurangabad



Sports Event under ACES (Association of Computer Engineering student) intra Branch for Computer Science & Engineering department.

**2021-22**

**SPORTS EVENT**

**10 May 2022 to 14 may 2022**

# Cricket

Sports Event was conducted during **10 May 2022 to 14 May 2022** at our college on departmental level for Computer Science and Engineering students. All the students were very much excited after all this was the time to enjoy beyond the studies. All have been selected for different events and started practicing and making them well and fit for the day.

All the students have taken part in those games which are their strengths as well as the game that they like. The students were already divided into different teams like **CSE TE(A), CSE TE(B), CSE SE(A) and CSE SE(B)**. On the day of the event, the Hon. Principal Sir inaugurated the program then the student started to set up the ground bat, ball, scoreboard and other things.

All the students started to compete with each other and the battle of winning and losing was set up. In the cricket match for the boys team, **team CSE TE(B) won the tournament by 15 runs.**















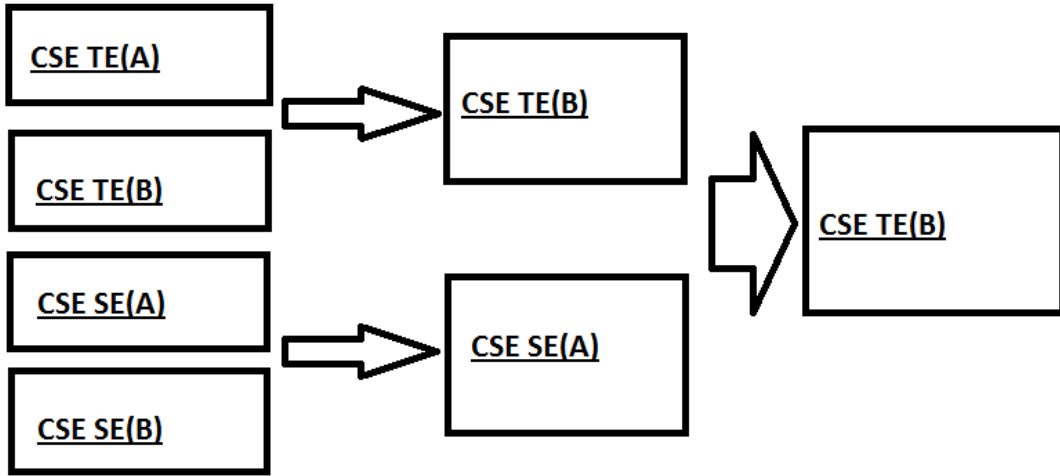

**Participant Teams:**

<b>CSE TE(A)</b>	<b>CSE TE(B)</b>
Swami Navnath(C)	Umesh Changulpaye(C)
Vivek Gathude	Akash Hajare
Akshay Talpate	Akash Bankar
Abhishek Sonawane	Sanket Chavhan
Rushikesh Malleshe	Sagar Vaishnav
Krushana Kayande	Govinda Salunke
Krushna Pathade	Giriraj Yelpalwar
Shubhamshing Chuadhari	Aditya Bembde
Swapnil Ruatrey	Ganesh Davkare
Gaurav Shah	Shubham Gaykawad
Prathamesh Pophle	Mayur Narke

<b>CSE SE(A)</b>	<b>CSE SE(B)</b>
Eshwar Chorghade	Aditya Sangule
Asit Sukhdhane(C)	Pranav Raut
Tukaram Padile	Saif Shaikh
Sunil Thale	Shubham Guakwar
Krishna Mohite	Amit Dound
Abhishek Bhujade	Mayur Tambat
Pravin Gorde	Manoj Goje
Ravindra Lasgare	Rahul Rathod(C)
Mahesh Lonkar	Sambhaji Shinde
Sunil Gurav	Tejandra Kulkarni
Suyash Babar	Tejas Dabhalkar
Krishna Pawar	Shivam Wagre

G. S. Wayal  
**Faculty Coordinator (ACES)**

Rokade A.H.  
**HOD(CSE Dept.)**

Pawar R.S.  
**Principal**

# VOLLEYBALL

The students were already divided into different teams like CSE TE(A),CSE TE(B),CSE SE(A) and CSE SE(B). The event inaugurated & then the student started to set up the ground VOLLEYBALL, scoreboard and other things.

The team started to compete with each other and the battle of winning and losing was set up. In the VOLLEYBALL match for the boys team.

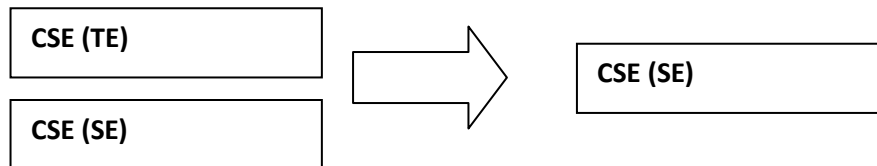

<b>PARTICIPANTS (TE)</b>	<b>PARTICIPANTS (SE)</b>
AKASH BANKAR	ASIT SUKHDHANE
VIVEK GATHUDE	TUKARAM PADILE
UMESH CHANGULPAY	ISHWAR CHORGHADDE
GOVINDA SALUNKE	KRISHNA PAWAR
ADITYA BEMBDE	PRASAD DEWARA
GIRIRAJ YALPALWAR	NIKHIL CHAVAN









G. S. Wayal  
Faculty Coordinator (ACES)

Rokade A.H.  
HOD(CSE Dept.)

Pawar R.S.  
Principal

# Chess

Intra Branch Matches & sports event was conducted during 10 May 2022 to 14 May 2022 in our college.

All the students were excited to enjoy while participating. All those participated were first registered their name to the co-ordinators and the lords have been selected for event.

It is the game make mind more sharp while to win the game of chess, a player must **capture the opponent's king**. This is known as "Checkmating" the king. Whenever the king is attacked, he is in check and must be so warned by the opponent.

. A game of chess ends when a player puts the opposing player's king in a position that cannot avoid capture (checkmate). A game can also be won or lost through concession. A chess match can also end in a draw. This can happen through stalemate, mutual consent, checkmate being impossible to achieve, and in other ways.







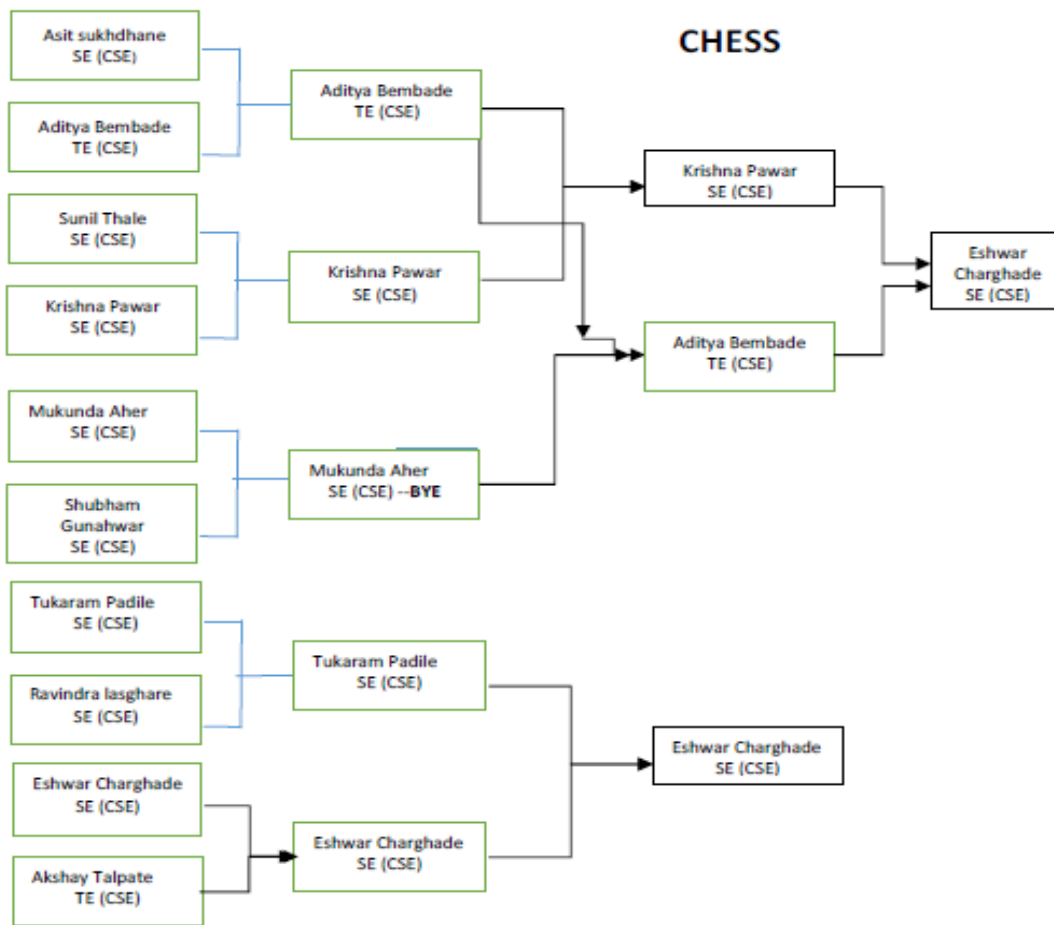

Final Match

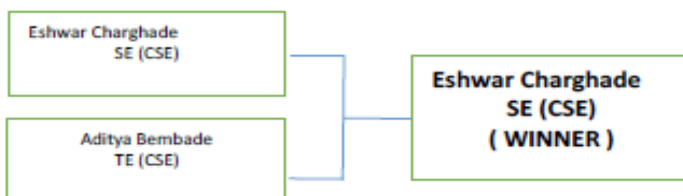

Winner Chess is Eshwar Charghade SE (CSE)  
 Runner Up Chess is: Aditya Bembade TE (CSE)

G. S. Woyal  
 Faculty Coordinator (ACES)

Rokade A.H.  
 HOD(CSE Dept.)

Pawar R.S.  
 Principal

# Carrom

It is an Indoor game; Carrom is a **tabletop game of Indian origin**. Carrom Matches were participated by student with great enthusiasm .





Participant for Carrom are as follows:

Boys

S.No.	Participants Name	Class
1	Rahul Rathod	SE CSE
2	Tejendra Kulkaeni	SE CSE
3	Sunil Thale	SE CSE
4	Mahesh Lonkar	SE CSE
5	sunil Gaurav	SE CSE
6	Shubham Tade	SE CSE
7	Akash Bankar	TE CSE
8	Gajanan Chavan	TE CSE

Girls

S.No.	Participants Name	Class
1	Divya Lahane	SE CSE
2	Deepali Ambhure	SE CSE
3	Sakshi Chunge	SE CSE
4	Sakshi Karchan	SE CSE
5	Rutuja Patil	TE CSE
6	Shruti Jagtap	SE CSE
7	Komal Rathod	SE CSE
8	Shital Rathod	SE CSE

Winner from CSE **Girls** team is: **Sakshi Chunge (SE CSE)**

Winner from CSE **Boys** team is **Akash Bankar (TE CSE)**

Runner Up from CSE **Girls** team is: **Komal Rathod (SE CSE)**

Runner Up from CSE **Boys** team is: **Tejender Kulkarni (SE CSE)**

G. S. Wayal  
Faculty Coordinator (ACES)

Rokade A.H.  
HOD(CSE Dept.)

Pawar R.S.  
Principal





**NAAC**  
NATIONAL ASSESSMENT AND  
ACCREDITATION COUNCIL



**Shreyash Pratishthan's**

# **Shreyash College of Engineering & Technology, Aurangabad**

Approved by AICTE (New Delhi) & DTE (Mumbai)  
Affiliated to Dr. Babasaheb Ambedkar Technological University, Lonere

## **Certificate of Appreciation**

This is to certify that

Mr/Miss. Shubham Chandane of Civil

Department has participated in Drama and secured

✓ First / Second / Participant position, conducted by SYCET, Aurangabad on  
the occasion of Cultural Annual Function **“RISING RHYTHM-2K22”**.

**MISSION EDUCATION**

**Prof. A. B. Vawhale**

Cultural In-charge

**Prof. Y. A. Kale**

Cultural In-charge

**Prof. M. M. Hanmanth**

Sports In-charge

**Dr. R. S. Pawar**

Principal



Shreeyash Pratishthan's  
**Shreeyash College of Engineering  
& Technology, Aurangabad**



Approved by AICTE (New Delhi) & DTE (Mumbai)  
Affiliated to Dr. Babasaheb Ambedkar Technological University, Lonere

# Certificate of Appreciation

This is to certify that

Mr/Miss. Rushika Aawte of ECE

Department has participated in Drama and secured  
First / Second / Participant position, conducted by SYCET, Aurangabad on  
the occasion of Cultural Annual Function "**RISING RHYTHM-2K22**".

MISSION EDUCATION

  
**Prof. A. B. Vawhale**  
Cultural In-charge

  
**Prof. Y. A. Kale**  
Cultural In-charge

  
**Prof. M. M. Hanmanth**  
Sports In-charge

  
**Dr. R. S. Pawar**  
Principal



Shreeyash Pratishthan's  
**Shreeyash College of Engineering  
& Technology, Aurangabad**



Approved by AICTE (New Delhi) & DTE (Mumbai)  
Affiliated to Dr. Babasaheb Ambedkar Technological University, Lonere

# Certificate of Appreciation

This is to certify that

Mr/Miss. Krishna Kayde of CS

Department has participated in Drama and secured  
First / Second / Participant position, conducted by SYCET, Aurangabad on  
the occasion of Cultural Annual Function **"RISING RHYTHM-2K22"**.

MISSION EDUCATION

  
**Prof. A. B. Vawhale**  
Cultural In-charge

  
**Prof. Y. A. Kale**  
Cultural In-charge

  
**Prof. M. M. Hanmanth**  
Sports In-charge

  
**Dr. R. S. Pawar**  
Principal

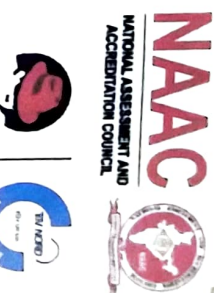

**Shreeyash Pratishthan's**  
**Shreeyash College of Engineering**  
**& Technology, Aurangabad**

Approved by AICTE (New Delhi) & DTE (Mumbai)  
Affiliated to Dr. Babasaheb Ambedkar Technological University, Lonere

# Certificate of Appreciation

This is to certify that

Mr/Miss. Mrunal Deshmukh of Civil

Department has participated in Dancing and secured

✓ First / Second / Participant position, conducted by SYCET, Aurangabad on  
the occasion of Cultural Annual Function "RISING RHYTHM-2K22".

MISSION EDUCATION

  
**Prof. A. B. Vawhale**  
Cultural In-charge

  
**Prof. Y. A. Kale**  
Cultural In-charge

  
**Prof. M. M. Hanmanth**  
Sports In-charge

  
**Dr. R. S. Pawar**  
Principal



# Shreeyash Pratishthan's Shreeyash College of Engineering & Technology, Aurangabad

Approved by AICTE (New Delhi) & DTE (Mumbai)  
Affiliated to Dr. Babasaheb Ambedkar Technological University, Lonere

## Certificate of Appreciation

This is to certify that

Mr/Miss. Arvind Jadhav of Civil

Department has participated in Singing and secured

First / Second / Participant position, conducted by SYCET, Aurangabad on  
the occasion of Cultural Annual Function **“RISING RHYTHM-2K22”**.

MISSION EDUCATION

  
Prof. A. B. Vawhale  
Cultural In-charge

  
Prof. Y. A. Kale  
Cultural In-charge

  
Prof. M. M. Hanmanth  
Sports In-charge

  
Dr. R. S. Pawar  
Principal



Shreyash Pratishthan's  
**Shreyash College of Engineering  
& Technology, Aurangabad**

Approved by AICTE (New Delhi) & DTE (Mumbai)  
Affiliated to Dr. Babasaheb Ambedkar Technological University, Lonere

# Certificate of Appreciation

This is to certify that

Mr/M<sup>ss</sup>. Ravikant Akote of EE

Department has participated in Mismatch Day and secured

First / Second / Participant position, conducted by SYCET, Aurangabad on  
the occasion of Cultural Annual Function "RISING RHYTHM-2K22".

MISSION EDUCATION

  
**Prof. A. B. Vawhale**  
Cultural In-charge

  
**Prof. Y. A. Kale**  
Cultural In-charge

  
**Prof. M. M. Hanmanth**  
Sports In-charge

  
**Dr. R. S. Pawar**  
Principal



Shreeyash Pratishthan's  
**Shreeyash College of Engineering  
& Technology, Aurangabad**



Approved by AICTE (New Delhi) & DTE (Mumbai)  
Affiliated to Dr. Babasaheb Ambedkar Technological University, Lonere



# Certificate of Appreciation

This is to certify that

Mr/Miss. Rupali Hewade of CSE

Department has participated in Western Day and secured  
First / Second / Participant position, conducted by SYCET, Aurangabad on  
the occasion of Cultural Annual Function "**RISING RHYTHM-2K22**".

MISSION EDUCATION

  
**Prof. A. B. Vawhale**  
Cultural In-charge

  
**Prof. Y. A. Kale**  
Cultural In-charge

  
**Prof. M. M. Hanmanth**  
Sports In-charge

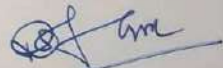
  
**Dr. R. S. Pawar**  
Principal



Shreeyash Pratishthan's  
**Shreeyash College of Engineering  
& Technology, Aurangabad**



Approved by AICTE (New Delhi) & DTE (Mumbai)  
Affiliated to Dr. Babasaheb Ambedkar Technological University, Lonere

## Certificate of Appreciation

This is to certify that

Mr/M<sup>ss</sup>. Vitthal Gole of CSE

Department has participated in Treasure Hunt and secured  
✓ First / Second / Participant position, conducted by SYCET, Aurangabad on  
the occasion of Cultural Annual Function "**RISING RHYTHM-2K22**".

MISSION EDUCATION

  
**Prof. A. B. Vawhale**  
Cultural In-charge

  
**Prof. Y. A. Kale**  
Cultural In-charge

  
**Prof. M. M. Hanmanth**  
Sports In-charge

  
**Dr. R. S. Pawar**  
Principal





Shreeyash Pratishthan's  
**Shreeyash College of Engineering  
& Technology, Aurangabad**



Approved by AICTE (New Delhi) & DTE (Mumbai)  
Affiliated to Dr. Babasaheb Ambedkar Technological University, Lonere

## Certificate of Appreciation

This is to certify that

Mr/M~~iss~~. Vitthal Gole of CSE

Department has participated in Group Day and secured  
✓ First / Second / Participant position, conducted by SYCET, Aurangabad on  
the occasion of Cultural Annual Function **"RISING RHYTHM-2K22"**.

MISSION EDUCATION

**Prof. A. B. Vawhale**  
Cultural In-charge

**Prof. Y. A. Kale**  
Cultural In-charge

**Prof. M. M. Hanmanth**  
Sports In-charge

**Dr. R. S. Pawar**  
Principal



Shreyash Pratishthan's  
**Shreyash College of Engineering  
& Technology, Aurangabad**

Approved by AICTE (New Delhi) & DTE (Mumbai)  
Affiliated to Dr. Babasaheb Ambedkar Technological University, Lonere



# Certificate of Appreciation

This is to certify that

Mr/Miss. Neha Zunje of Civil

Department has participated in Singing and secured  
First / Second / Participant position, conducted by SYCET, Aurangabad on  
the occasion of Cultural Annual Function **"RISING RHYTHM-2K22"**.

MISSION EDUCATION

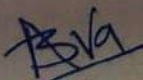
  
**Prof. A. B. Vawhale**  
Cultural In-charge

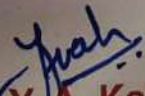
  
**Prof. Y. A. Kale**  
Cultural In-charge

  
**Prof. M. M. Hanmanth**  
Sports In-charge

  
**Dr. R. S. Pawar**  
Principal

2022/6/11 22:07

REDMI NOTE 6 PRO  
MI DUAL CAMERA



Shreeyash Pratishthan's  
**Shreeyash College of Engineering  
& Technology, Aurangabad**

Approved by AICTE (New Delhi) & DTE (Mumbai)  
Affiliated to Dr. Babasaheb Ambedkar Technological University, Lonere



# Certificate of Appreciation

This is to certify that

Mr/Miss. Payal Yadav of ESTC

Department has participated in Dancing and secured  
First /  Second / Participant position, conducted by SYCET, Aurangabad on  
the occasion of Cultural Annual Function "RISING RHYTHM-2K22".

MISSION EDUCATION

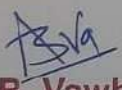
  
Prof. A. B. Vawhale  
Cultural In-charge

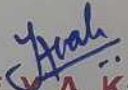
  
Prof. Y. A. Kale  
Cultural In-charge

  
Prof. M. M. Hanmanth  
Sports In-charge

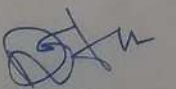
  
Dr. R. S. Pawar  
Principal



Shreeyash Pratishthan's  
**Shreeyash College of Engineering  
& Technology, Aurangabad**



Approved by AICTE (New Delhi) & DTE (Mumbai)  
Affiliated to Dr. Babasaheb Ambedkar Technological University, Lonere

## Certificate of Appreciation

This is to certify that

Mr/M~~iss~~. Sahil Kachre of EE

Department has participated in Treasure Hunt and secured  
✓  
First / Second / Participant position, conducted by SYCET, Aurangabad on  
the occasion of Cultural Annual Function "**RISING RHYTHM-2K22**".

MISSION EDUCATION

**Prof. A. B. Vawhale**  
Cultural In-charge

  
**Prof. Y. A. Kale**  
Cultural In-charge

**Prof. M. M. Hanmanth**  
Sports In-charge

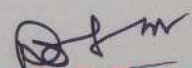
  
**Dr. R. S. Pawar**  
Principal



Shreeyash Pratishthan's  
**Shreeyash College of Engineering  
& Technology, Aurangabad**



Approved by AICTE (New Delhi) & DTE (Mumbai)  
Affiliated to Dr. Babasaheb Ambedkar Technological University, Lonere

## Certificate of Appreciation

This is to certify that

Mr/M~~iss~~. Pranav Raut of CSE

Department has participated in Group Day and secured  
✓ First / Second / Participant position, conducted by SYCET, Aurangabad on  
the occasion of Cultural Annual Function "**RISING RHYTHM-2K22**".

MISSION EDUCATION

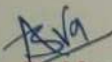
  
**Prof. A. B. Vawhale**  
Cultural In-charge

  
**Prof. Y. A. Kale**  
Cultural In-charge

  
**Prof. M. M. Hanmanth**  
Sports In-charge

  
**Dr. R. S. Pawar**  
Principal



Shreyash Pratishthan's  
**Shreyash College of Engineering  
& Technology, Aurangabad**



Approved by AICTE (New Delhi) & DTE (Mumbai)  
Affiliated to Dr. Babasaheb Ambedkar Technological University, Lonere

## Certificate of Appreciation

This is to certify that

Mr/M~~iss~~. Shubham Tadhar of CSE

Department has participated in Treasure Hunt and secured  
✓ First / Second / Participant position, conducted by SYCET, Aurangabad on  
the occasion of Cultural Annual Function "RISING RHYTHM-2K22",

MISSION EDUCATION

**Prof. A. B. Vawhale**  
Cultural In-charge

*A. B. Vawhale*  
**Prof. V. A. Kale**  
Cultural In-charge

**Prof. M. M. Hanmanth**  
Sports In-charge

*R. S. Pawar*  
**Dr. R. S. Pawar**  
Principal



Shreeyash Pratishthan's  
**Shreeyash College of Engineering  
& Technology, Aurangabad**



Approved by AICTE (New Delhi) & DTE (Mumbai)  
Affiliated to Dr. Babasaheb Ambedkar Technological University, Lonere

## Certificate of Appreciation

This is to certify that

Mr/M~~iss~~. Pranav Raut of CSE  
Department has participated in Treasure Hunt and secured  
 First /  Second / Participant position, conducted by SYCET, Aurangabad on  
the occasion of Cultural Annual Function "RISING RHYTHM-2K22".

**Prof. A. B. Vawhale**  
Cultural In-charge

**Prof. Y. A. Kale**  
Cultural In-charge

**Prof. M. M. Hanmanth**  
Sports In-charge

**Dr. R. S. Pawar**  
Principal



Shreeyash Pratishthan's  
**Shreeyash College of Engineering  
& Technology, Aurangabad**



Approved by AICTE (New Delhi) & DTE (Mumbai)  
Affiliated to Dr. Babasaheb Ambedkar Technological University, Lonere

## Certificate of Appreciation

This is to certify that

Mr/M~~iss~~. Pranav Raut of CSE  
Department has participated in Treasure Hunt and secured  
 First /  Second / Participant position, conducted by SYCET, Aurangabad on  
the occasion of Cultural Annual Function "RISING RHYTHM-2K22".

**Prof. A. B. Vawhale**  
Cultural In-charge

**Prof. Y. A. Kale**  
Cultural In-charge

**Prof. M. M. Hanmanth**  
Sports In-charge

**Dr. R. S. Pawar**  
Principal





Shreeyash Pratishthan's  
**Shreeyash College of Engineering  
& Technology, Aurangabad**

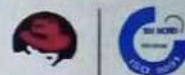

Approved by AICTE (New Delhi) & DTE (Mumbai)  
Affiliated to Dr. Babasaheb Ambedkar Technological University, Lonere

## Certificate of Appreciation

This is to certify that

Mr/M<sup>rs</sup>. Onkar Jogas of Electrical  
Department has participated in Treasure Hunt and secured  
 First /  Second /  Participant position, conducted by SYCET, Aurangabad on  
the occasion of Cultural Annual Function "**RISING RHYTHM-2K22**".

MISSION EDUCATION

**Prof. A. B. Vawhale**  
Cultural In-charge

**Prof. Y. A. Kale**  
Cultural In-charge

**Prof. M. M. Hanmanth**  
Sports In-charge

**Dr. R. S. Pawar**  
Principal



Shreeyash Pratishtan's  
**Shreeyash College of Engineering  
& Technology, Aurangabad**

Approved by AICTE (New Delhi) & DTE (Mumbai)  
Affiliated to Dr. Babasaheb Ambedkar Technological University, Lonere



# Certificate of Appreciation

This is to certify that

Mr/M<sup>ss</sup>. Shubham Ganakwar of CSE

Department has participated in Treasure Hunt and secured  
✓ First / Second / Participant position, conducted by SYCET, Aurangabad on  
the occasion of Cultural Annual Function "**RISING RHYTHM-2K22**".

MISSION EDUCATION

**Prof. A. B. Vawhale**  
Cultural In-charge

  
**Prof. Y. A. Kale**  
Cultural In-charge

**Prof. M. M. Hanmanth**  
Sports In-charge

  
**Dr. R. S. Pawar**  
Principal

Scanned with  
CamScanner



Shreeyash Pratishthan's  
**Shreeyash College of Engineering  
& Technology, Aurangabad**



Approved by AICTE (New Delhi) & DTE (Mumbai)  
Affiliated to Dr. Babasaheb Ambedkar Technological University, Lonere

## Certificate of Appreciation

This is to certify that

Mr/Miss. Rahul santosh Bansode of E & Tc

Department has participated in Drama and secured

First / Second / Participant position, conducted by SYCET, Aurangabad on  
the occasion of Cultural Annual Function "**RISING RHYTHM-2K22**".

MISSION EDUCATION

  
**Prof. A. B. Vawhale**  
Cultural In-charge

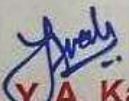
  
**Prof. Y. A. Kale**  
Cultural In-charge

  
**Prof. M. M. Hanmanth**  
Sports In-charge

  
**Dr. R. S. Pawar**  
Principal



Shreeyash Pratishthan's  
**Shreeyash College of Engineering  
& Technology, Aurangabad**



Approved by AICTE (New Delhi) & DTE (Mumbai)  
Affiliated to Dr. Babasaheb Ambedkar Technological University, Lonere

## Certificate of Appreciation

This is to certify that

Mr/Miss. Yogita Hiwale of \_\_\_\_\_

Department has participated in Bachpan Day and secured  
First /  Second / Participant position, conducted by SYCET, Aurangabad on  
the occasion of Cultural Annual Function "**RISING RHYTHM-2K22**".

MISSION EDUCATION

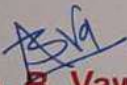
  
**Prof. A. B. Vawhale**  
Cultural In-charge

  
**Prof. Y. A. Kale**  
Cultural In-charge

  
**Prof. M. M. Hanmanth**  
Sports In-charge

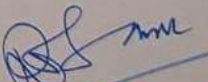
  
**Dr. R. S. Pawar**  
Principal



Shreeyash Pratishthan's  
**Shreeyash College of Engineering  
& Technology, Aurangabad**

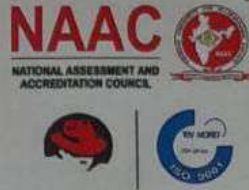

Approved by AICTE (New Delhi) & DTE (Mumbai)  
Affiliated to Dr. Babasaheb Ambedkar Technological University, Lonere

# Certificate of Appreciation

This is to certify that

Mr/M<sup>iss</sup>. Tejendra Kulkarni of CSE

Department has participated in Singing and secured  
✓ First / Second / Participant position, conducted by SYCET, Aurangabad on  
the occasion of Cultural Annual Function **"RISING RHYTHM-2K22"**.

MISSION EDUCATION

  
**Prof. A. B. Vawhale**  
Cultural In-charge

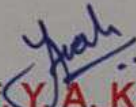
  
**Prof. Y. A. Kale**  
Cultural In-charge

  
**Prof. M. M. Hanmanth**  
Sports In-charge

  
**Dr. R. S. Pawar**  
Principal



Shreeyash Pratishthan's  
**Shreeyash College of Engineering  
& Technology, Aurangabad**



Approved by AICTE (New Delhi) & DTE (Mumbai)  
Affiliated to Dr. Babasaheb Ambedkar Technological University, Lonere

# Certificate of Appreciation

This is to certify that

Mr/Miss. Tejendra Kulkarni of CSE

Department has participated in Filmy Day and secured

✓ First / Second / Participant position, conducted by SYCET, Aurangabad on

the occasion of Cultural Annual Function "**RISING RHYTHM-2K22**".

MISSION EDUCATION

  
**Prof. A. B. Vawhale**  
Cultural In-charge

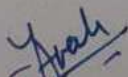
  
**Prof. Y. A. Kale**  
Cultural In-charge

  
**Prof. M. M. Hanmanth**  
Sports In-charge

  
**Dr. R. S. Pawar**  
Principal



Shreeyash Pratishthan's  
**Shreeyash College of Engineering  
& Technology, Aurangabad**



Approved by AICTE (New Delhi) & DTE (Mumbai)  
Affiliated to Dr. Babasaheb Ambedkar Technological University, Lonere

# Certificate of Appreciation

This is to certify that

Mr/M<sup>iss</sup>. Prashant Gaikwad of CSE

Department has participated in Treasure Hunt and secured  
First / Second / Participant position, conducted by SYCET, Aurangabad on  
the occasion of Cultural Annual Function **"RISING RHYTHM-2K22"**.

MISSION EDUCATION

**Prof. A. B. Vawhale**  
Cultural In-charge

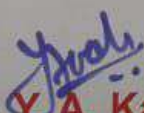
  
**Prof. Y. A. Kale**  
Cultural In-charge

**Prof. M. M. Hanmanth**  
Sports In-charge

  
**Dr. R. S. Pawar**  
Principal



Shreyash Pratishthan's  
**Shreyash College of Engineering  
& Technology, Aurangabad**



Approved by AICTE (New Delhi) & DTE (Mumbai)  
Affiliated to Dr. Babasaheb Ambedkar Technological University, Lonere

# Certificate of Appreciation

This is to certify that

Mr/M<sup>ss</sup>. Prashant Gaikwad of CSE

Department has participated in Group Day and secured  
✓ First / Second / Participant position, conducted by SYCET, Aurangabad on  
the occasion of Cultural Annual Function "**RISING RHYTHM-2K22**".

MISSION EDUCATION

**Prof. A. B. Vawhale**  
Cultural In-charge

**Prof. Y. A. Kale**  
Cultural In-charge

**Prof. M. M. Hanmanth**  
Sports In-charge

**Dr. R. S. Pawar**  
Principal





Shreeyash Pratishthan's  
**Shreeyash College of Engineering  
& Technology, Aurangabad**



Approved by AICTE (New Delhi) & DTE (Mumbai)  
Affiliated to Dr. Babasaheb Ambedkar Technological University, Lonere

## Certificate of Appreciation

This is to certify that

Mr/M<sup>rs</sup>. Tukaram Padile of CSE

Department has participated in Bachpan Day and secured  
First / Second / Participant position, conducted by SYCET, Aurangabad on  
the occasion of Cultural Annual Function "**RISING RHYTHM-2K22**".

MISSION EDUCATION

  
**Prof. A. B. Vawhale**  
Cultural In-charge

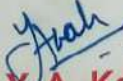
  
**Prof. Y. A. Kale**  
Cultural In-charge

  
**Prof. M. M. Hanmanth**  
Sports In-charge

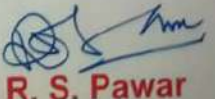
  
**Dr. R. S. Pawar**  
Principal



**Shreeyash Pratishthan's**  
**Shreeyash College of Engineering**  
**& Technology, Aurangabad**



Approved by AICTE (New Delhi) & DTE (Mumbai)  
Affiliated to Dr. Babasaheb Ambedkar Technological University, Lonere

# Certificate of Appreciation

This is to certify that

Mr/Miss. Yogesh Rathod of EE

Department has participated in Chess and secured

First / Second / Participant position, conducted by SYCET, Aurangabad on  
the occasion of Cultural Annual Function **“RISING RHYTHM-2K22”**.

**MISSION EDUCATION**

**Prof. A. B. Vawhale**  
Cultural In-charge

**Prof. Y. A. Kale**  
Cultural In-charge

**Prof. M. M. Hanmanth**  
Sports In-charge

**Dr. R. S. Pawar**  
Principal



Shreeyash Pratishthan's  
**Shreeyash College of Engineering  
& Technology, Aurangabad**



Approved by AICTE (New Delhi) & DTE (Mumbai)  
Affiliated to Dr. Babasaheb Ambedkar Technological University, Lonere

# Certificate of Appreciation

This is to certify that

Mr/M<sup>iss</sup>. Dnyaneshwar Parasram Chavan of Civil

Department has participated in Cricknet and secured

✓ First / Second / Participant position, conducted by SYCET, Aurangabad on

the occasion of Cultural Annual Function **"RISING RHYTHM-2K22"**.

MISSION EDUCATION

**Prof. A. B. Vawhale**

Cultural In-charge

**Prof. Y. A. Kale**

Cultural In-charge

**Prof. M. M. Hanmanth**

Sports In-charge

**Dr. R. S. Pawar**

Principal



Shreeyash Pratishtan's

# Shreeyash College of Engineering & Technology, Aurangabad

Approved by AICTE (New Delhi) & DTE (Mumbai)  
Affiliated to Dr. Babasaheb Ambedkar Technological University, Lonere

**NAAC**  
NATIONAL ASSESSMENT AND  
ACCREDITATION COUNCIL



## Certificate of Appreciation

This is to certify that

Mr/M<sup>iss</sup>. Ajay Raju Chavan of Civil

Department has participated in Cricket and secured

First / Second / Participant position, conducted by SYCET, Aurangabad on  
the occasion of Cultural Annual Function **"RISING RHYTHM-2K22"**.

MISSION EDUCATION

**Prof. A. B. Vawhale**  
Cultural In-charge

**Prof. Y. A. Kale**  
Cultural In-charge

**Prof. M. M. Hanmanth**  
Sports In-charge

**Dr. R. S. Pawar**  
Principal



Shreeyash Pratishtan's  
**Shreeyash College of Engineering  
& Technology, Aurangabad**



Approved by AICTE (New Delhi) & DTE (Mumbai)  
Affiliated to Dr. Babasaheb Ambedkar Technological University, Lonere

# Certificate of Appreciation

This is to certify that

Mr/M/Js. Avinash Devichand chavan of Civil

Department has participated in Cricket and secured

✓ First / Second / Participant position, conducted by SYCET, Aurangabad on

the occasion of Cultural Annual Function **“RISING RHYTHM-2K22”**.

MISSION EDUCATION

**Prof. A. B. Vawhale**

Cultural In-charge

**Prof. Y. A. Kale**

Cultural In-charge

**Prof. M. M. Hanmanth**

Sports In-charge

**Dr. R. S. Pawar**

Principal



Shreeyash Pratishthan's  
**Shreeyash College of Engineering  
& Technology, Aurangabad**



Approved by AICTE (New Delhi) & DTE (Mumbai)  
Affiliated to Dr. Babasaheb Ambedkar Technological University, Lonere

# Certificate of Appreciation

This is to certify that

Mr/Mi~~ss~~. Vaibhav Bhimrao Rathod of Civil

Department has participated in Cricket and secured

✓ First / Second / Participant position, conducted by SYCET, Aurangabad on  
the occasion of Cultural Annual Function **“RISING RHYTHM-2K22”**.

MISSION EDUCATION

**Prof. A. B. Vawhale**  
Cultural In-charge

**Prof. Y. A. Kale**  
Cultural In-charge

**Prof. M. M. Hanmanth**  
Sports In-charge

**Dr. R. S. Pawar**  
Principal



Shreyash Pratishtan's  
**Shreyash College of Engineering  
& Technology, Aurangabad**



Approved by AICTE (New Delhi) & DTE (Mumbai)  
Affiliated to Dr. Babasaheb Ambedkar Technological University, Lonere

# Certificate of Appreciation

This is to certify that

Mr/M<sup>iss</sup>. Sajid Majid Shaikh of Civil

Department has participated in Cricket and secured

✓ First / Second / Participant position, conducted by SYCET, Aurangabad on  
the occasion of Cultural Annual Function **“RISING RHYTHM-2K22”**.

MISSION EDUCATION

**Prof. A. B. Vawhale**  
Cultural In-charge

**Prof. Y. A. Kale**  
Cultural In-charge

**Prof. M. M. Hanmanth**  
Sports In-charge

**Dr. R. S. Pawar**  
Principal



Shreeyash Pratishthan's  
**Shreeyash College of Engineering  
& Technology, Aurangabad**



Approved by AICTE (New Delhi) & DTE (Mumbai)  
Affiliated to Dr. Babasaheb Ambedkar Technological University, Lonere

# Certificate of Appreciation

This is to certify that

Mr/Ms. Niranjan Gokul Chavan of Civil

Department has participated in Cricket and secured

✓ First / Second / Participant position, conducted by SYCET, Aurangabad on  
the occasion of Cultural Annual Function **“RISING RHYTHM-2K22”**.

MISSION EDUCATION

**Prof. A. B. Vawhale**

Cultural In-charge

**Prof. Y. A. Kale**

Cultural In-charge

**Prof. M. M. Hanmanth**

Sports In-charge

**Dr. R. S. Pawar**

Principal





Shreeyash Pratishthan's  
**Shreeyash College of Engineering  
& Technology, Aurangabad**



Approved by AICTE (New Delhi) & DTE (Mumbai)  
Affiliated to Dr. Babasaheb Ambedkar Technological University, Lonere

# Certificate of Appreciation

This is to certify that

Mr/M<sup>rs</sup>. Abhijit Shendre of Civil

Department has participated in Cricket and secured

✓ First / Second / Participant position, conducted by SYCET, Aurangabad on  
the occasion of Cultural Annual Function **“RISING RHYTHM-2K22”**.

MISSION EDUCATION

**Prof. A. B. Vawhale**  
Cultural In-charge

**Prof. Y. A. Kale**  
Cultural In-charge

**Prof. M. M. Hanmanth**  
Sports In-charge

**Dr. R. S. Pawar**  
Principal



Shreeyash Pratishtan's  
**Shreeyash College of Engineering  
& Technology, Aurangabad**



Approved by AICTE (New Delhi) & DTE (Mumbai)  
Affiliated to Dr. Babasaheb Ambedkar Technological University, Lonere

# Certificate of Appreciation

This is to certify that

Mr/Mi/s. Rohidas Kakade of Civil

Department has participated in Cricket and secured

✓ First / Second / Participant position, conducted by SYCET, Aurangabad on

the occasion of Cultural Annual Function **“RISING RHYTHM-2K22”**.

MISSION EDUCATION

**Prof. A. B. Vawhale**  
Cultural In-charge

**Prof. Y. A. Kale**  
Cultural In-charge

**Prof. M. M. Hanmanth**  
Sports In-charge

**Dr. R. S. Pawar**  
Principal



Shreeyash Pratishtan's  
**Shreeyash College of Engineering  
& Technology, Aurangabad**



Approved by AICTE (New Delhi) & DTE (Mumbai)  
Affiliated to Dr. Babasaheb Ambedkar Technological University, Lonere

# Certificate of Appreciation

This is to certify that

Mr/M/sss. Avinash Misal of Civil

Department has participated in Cricket and secured  
✓ First / Second / Participant position, conducted by SYCET, Aurangabad on  
the occasion of Cultural Annual Function **“RISING RHYTHM-2K22”**.

## MISSION EDUCATION

**Prof. A. B. Vawhale**  
Cultural In-charge

**Prof. Y. A. Kale**  
Cultural In-charge

**Prof. M. M. Hanmanth**  
Sports In-charge

**Dr. R. S. Pawar**  
Principal



Shreeyash Pratishthan's  
**Shreeyash College of Engineering  
& Technology, Aurangabad**



Approved by AICTE (New Delhi) & DTE (Mumbai)  
Affiliated to Dr. Babasaheb Ambedkar Technological University, Lonere

# Certificate of Appreciation

This is to certify that

Mr/M<sup>iss</sup>. Sameer Patil of Civil

Department has participated in Cricket and secured

First / Second / Participant position, conducted by SYCET, Aurangabad on  
the occasion of Cultural Annual Function **“RISING RHYTHM-2K22”**.

MISSION EDUCATION

**Prof. A. B. Vawhale**  
Cultural In-charge

**Prof. Y. A. Kale**  
Cultural In-charge

**Prof. M. M. Hanmanth**  
Sports In-charge

**Dr. R. S. Pawar**  
Principal



Shreeyash Pratishtan's  
**Shreeyash College of Engineering  
& Technology, Aurangabad**



Approved by AICTE (New Delhi) & DTE (Mumbai)  
Affiliated to Dr. Babasaheb Ambedkar Technological University, Lonere

# Certificate of Appreciation

This is to certify that

Mr/M<sup>ss</sup>. Bharat Subhdev Chaudhary of Civil

Department has participated in Cricket and secured

✓ First / Second / Participant position, conducted by SYCET, Aurangabad on

the occasion of Cultural Annual Function **“RISING RHYTHM-2K22”**.

MISSION EDUCATION

**Prof. A. B. Vawhale**

Cultural In-charge

**Prof. Y. A. Kale**

Cultural In-charge

**Prof. M. M. Hanmanth**

Sports In-charge

**Dr. R. S. Pawar**

Principal



Shreeyash Pratishthan's  
**Shreeyash College of Engineering  
& Technology, Aurangabad**



Approved by AICTE (New Delhi) & DTE (Mumbai)  
Affiliated to Dr. Babasaheb Ambedkar Technological University, Lonere

# Certificate of Appreciation

This is to certify that

Mr/M<sup>iss</sup>. Prabuddha Mabik Waghmare of Civil

Department has participated in Cricket and secured

First / Second / Participant position, conducted by SYCET, Aurangabad on  
the occasion of Cultural Annual Function **“RISING RHYTHM-2K22”**.

MISSION EDUCATION

**Prof. A. B. Vawhale**

Cultural In-charge

**Prof. Y. A. Kale**

Cultural In-charge

**Prof. M. M. Hanmanth**

Sports In-charge

**Dr. R. S. Pawar**

Principal



Shreeyash Pratishtan's  
**Shreeyash College of Engineering  
& Technology, Aurangabad**



Approved by AICTE (New Delhi) & DTE (Mumbai)  
Affiliated to Dr. Babasaheb Ambedkar Technological University, Lonere

# Certificate of Appreciation

This is to certify that

Mr/M<sup>iss</sup>. Sujit Bbagwat Jante of Civil

Department has participated in Cricket and secured

✓ First / Second / Participant position, conducted by SYCET, Aurangabad on  
the occasion of Cultural Annual Function **“RISING RHYTHM-2K22”**.

MISSION EDUCATION

**Prof. A. B. Vawhale**  
Cultural In-charge

**Prof. Y. A. Kale**  
Cultural In-charge

**Prof. M. M. Hanmanth**  
Sports In-charge

**Dr. R. S. Pawar**  
Principal



Shreeyash Pratishtan's  
**Shreeyash College of Engineering  
& Technology, Aurangabad**



Approved by AICTE (New Delhi) & DTE (Mumbai)  
Affiliated to Dr. Babasaheb Ambedkar Technological University, Lonere

# Certificate of Appreciation

This is to certify that

Mr/M<sup>iss</sup>. Rohit Vilasrao Shinde of Civil

Department has participated in Cricket and secured

✓ First / Second / Participant position, conducted by SYCET, Aurangabad on  
the occasion of Cultural Annual Function **“RISING RHYTHM-2K22”**.

MISSION EDUCATION

**Prof. A. B. Vawhale**  
Cultural In-charge

**Prof. Y. A. Kale**  
Cultural In-charge

**Prof. M. M. Hanmanth**  
Sports In-charge

**Dr. R. S. Pawar**  
Principal





Shreeyash Pratishthan's  
**Shreeyash College of Engineering  
& Technology, Aurangabad**



Approved by AICTE (New Delhi) & DTE (Mumbai)  
Affiliated to Dr. Babasaheb Ambedkar Technological University, Lonere

# Certificate of Appreciation

This is to certify that

Mr/M~~iss~~. Satish Bibade of Civil

Department has participated in Cricket and secured

✓ First / Second / Participant position, conducted by SYCET, Aurangabad on  
the occasion of Cultural Annual Function **“RISING RHYTHM-2K22”**.

MISSION EDUCATION

**Prof. A. B. Vawhale**  
Cultural In-charge

**Prof. Y. A. Kale**  
Cultural In-charge

**Prof. M. M. Hanmanth**  
Sports In-charge

**Dr. R. S. Pawar**  
Principal



Shreeyash Pratishthan's  
**Shreeyash College of Engineering  
& Technology, Aurangabad**



Approved by AICTE (New Delhi) & DTE (Mumbai)  
Affiliated to Dr. Babasaheb Ambedkar Technological University, Lonere

# Certificate of Appreciation

This is to certify that

Mr/Miss. Roshan Rathod of CSE

Department has participated in Kabaddi and secured

✓ First / Second / Participant position, conducted by SYCET, Aurangabad on  
the occasion of Cultural Annual Function **"RISING RHYTHM-2K22"**.

MISSION EDUCATION

**Prof. A. B. Vawhale**  
Cultural In-charge

**Prof. Y. A. Kale**  
Cultural In-charge

**Prof. M. M. Hanmanth**  
Sports In-charge

**Dr. R. S. Pawar**  
Principal



Shreeyash Pratishthan's  
**Shreeyash College of Engineering  
& Technology, Aurangabad**

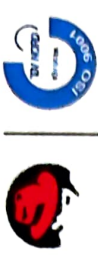

Approved by AICTE (New Delhi) & DTE (Mumbai)  
Affiliated to Dr. Babasaheb Ambedkar Technological University, Lonere

# Certificate of Appreciation

This is to certify that

Mr/M~~is~~ss. Sachin Dole of CSE

Department has participated in Kabaddi and secured

First / Second / Participant position, conducted by SYCET, Aurangabad on  
the occasion of Cultural Annual Function **"RISING RHYTHM-2K22"**.

MISSION EDUCATION

**Prof. A. B. Vawhale**  
Cultural In-charge

**Prof. Y. A. Kale**  
Cultural In-charge

**Prof. M. M. Hanmanth**  
Sports In-charge

**Dr. R. S. Pawar**  
Principal



Shreeyash Pratishthan's  
**Shreeyash College of Engineering  
& Technology, Aurangabad**



Approved by AICTE (New Delhi) & DTE (Mumbai)  
Affiliated to Dr. Babasaheb Ambedkar Technological University, Lonere

# Certificate of Appreciation

This is to certify that

Mr/M~~is~~ss. Bharat Chaudhari of Civil

Department has participated in Kabaddi and secured

✓ First / Second / Participant position, conducted by SYCET, Aurangabad on  
the occasion of Cultural Annual Function **“RISING RHYTHM-2K22”**.

MISSION EDUCATION

**Prof. A. B. Vawhale**  
Cultural In-charge

**Prof. Y. A. Kale**  
Cultural In-charge

**Prof. M. M. Hanmanth**  
Sports In-charge

**Dr. R. S. Pawar**  
Principal



Shreeyash Pratishtan's

# Shreeyash College of Engineering & Technology, Aurangabad

Approved by AICTE (New Delhi) & DTE (Mumbai)  
Affiliated to Dr. Babasaheb Ambedkar Technological University, Lonere



## Certificate of Appreciation

This is to certify that

Mr/M<sup>iss</sup>. Aditya Narayan Sangule of CSE

Department has participated in Kabaddi and secured

✓ First / Second / Participant position, conducted by SYCET, Aurangabad on  
the occasion of Cultural Annual Function **“RISING RHYTHM-2K22”**.

MISSION EDUCATION

**Prof. A. B. Vawhale**

Cultural In-charge

**Prof. Y. A. Kale**

Cultural In-charge

**Prof. M. M. Hanmanth**

Sports In-charge

**Dr. R. S. Pawar**

Principal



Shreeyash Pratishthan's  
**Shreeyash College of Engineering  
& Technology, Aurangabad**



Approved by AICTE (New Delhi) & DTE (Mumbai)  
Affiliated to Dr. Babasaheb Ambedkar Technological University, Lonere

# Certificate of Appreciation

This is to certify that

Mr/Mr<sup>ss</sup>. Omkar Appasaheb Hapase of CSE

Department has participated in Kabaddi and secured

✓ First / Second / Participant position, conducted by SYCET, Aurangabad on  
the occasion of Cultural Annual Function **“RISING RHYTHM-2K22”**.

MISSION EDUCATION

**Prof. A. B. Vawhale**

Cultural In-charge

**Prof. Y. A. Kale**

Cultural In-charge

**Prof. M. M. Hanmanth**

Sports In-charge

**Dr. R. S. Pawar**

Principal



**Shreeyash Pratishthan's**  
**Shreeyash College of Engineering**  
**& Technology, Aurangabad**



Approved by AICTE (New Delhi) & DTE (Mumbai)  
Affiliated to Dr. Babasaheb Ambedkar Technological University, Lonere

# Certificate of Appreciation

This is to certify that

Mr/Miss. Akash Suresh Hajare of CSE

Department has participated in Kabaddi and secured  
First / Second / Participant position, conducted by SYCET, Aurangabad on  
the occasion of Cultural Annual Function **"RISING RHYTHM-2K22"**.

MISSION EDUCATION

**Prof. A. B. Vawhale**  
Cultural In-charge

**Prof. Y. A. Kale**  
Cultural In-charge

**Prof. M. M. Hanmanth**  
Sports In-charge

**Dr. R. S. Pawar**  
Principal



Shreeyash Pratishthan's  
**Shreeyash College of Engineering  
& Technology, Aurangabad**



Approved by AICTE (New Delhi) & DTE (Mumbai)  
Affiliated to Dr. Babasaheb Ambedkar Technological University, Lonere

# Certificate of Appreciation

This is to certify that

Mr/M<sup>ss</sup>. Akash Bankar of CSE

Department has participated in Kabaddi and secured

✓ First / Second / Participant position, conducted by SYCET, Aurangabad on  
the occasion of Cultural Annual Function **“RISING RHYTHM-2K22”**.

MISSION EDUCATION

**Prof. A. B. Vawhale**  
Cultural In-charge

**Prof. Y. A. Kale**  
Cultural In-charge

**Prof. M. M. Hanmanth**  
Sports In-charge

**Dr. R. S. Pawar**  
Principal





Shreyash Pratishtan's  
**Shreyash College of Engineering  
& Technology, Aurangabad**

Approved by AICTE (New Delhi) & DTE (Mumbai)  
Affiliated to Dr. Babasaheb Ambedkar Technological University, Lonere



# Certificate of Appreciation

This is to certify that

Mr/Miss. Roshan Rathod of CSE

Department has participated in Kabaddi and secured

First / Second / Participant position, conducted by SYCET, Aurangabad on  
the occasion of Cultural Annual Function **"RISING RHYTHM-2K22"**.

MISSION EDUCATION

**Prof. A. B. Vawhale**  
Cultural In-charge

**Prof. Y. A. Kale**  
Cultural In-charge

**Prof. M. M. Hanmanth**  
Sports In-charge

**Dr. R. S. Pawar**  
Principal



Shreeyash Pratishthan's  
**Shreeyash College of Engineering  
& Technology, Aurangabad**



Approved by AICTE (New Delhi) & DTE (Mumbai)  
Affiliated to Dr. Babasaheb Ambedkar Technological University, Lonere

# Certificate of Appreciation

This is to certify that

Mr/M<sup>iss</sup>. Akshay Gopal Sarode of Electrical

Department has participated in Volleyball and secured  
First / Second / Participant position, conducted by SYCET, Aurangabad on  
the occasion of Cultural Annual Function "**RIISING RHYTHM-2K22**".

MISSION EDUCATION

**Prof. A. B. Vawhale**  
Cultural In-charge

**Prof. Y. A. Kale**  
Cultural In-charge

**Prof. M. M. Hanmanth**  
Sports In-charge

**Dr. R. S. Pawar**  
Principal



Shreeyash Pratishtan's  
**Shreeyash College of Engineering  
& Technology, Aurangabad**



Approved by AICTE (New Delhi) & DTE (Mumbai)  
Affiliated to Dr. Babasaheb Ambedkar Technological University, Lonere

# Certificate of Appreciation

This is to certify that

Mr/Miss. Ajay Ramdas Rathod of Electrical  
Department has participated in Volleyball and secured  
First / Second / Participant position, conducted by SYCET, Aurangabad on  
the occasion of Cultural Annual Function "**RISING RHYTHM-2K22**".

MISSION EDUCATION

**Prof. A. B. Vawhale**  
Cultural In-charge

**Prof. Y. A. Kale**  
Cultural In-charge

**Prof. M. M. Hanmanth**  
Sports In-charge

**Dr. R. S. Pawar**  
Principal



Shreyash Pratishthan's  
**Shreyash College of Engineering  
& Technology, Aurangabad**



Approved by AICTE (New Delhi) & DTE (Mumbai)  
Affiliated to Dr. Babasaheb Ambedkar Technological University, Lonere

# Certificate of Appreciation

This is to certify that

Mr/Miss. Shubham Shankar Makode of Electrical

Department has participated in Volleyball and secured

First / Second / Participant position, conducted by SYCET, Aurangabad on

the occasion of Cultural Annual Function "**RISING RHYTHM-2K22**".

## MISSION EDUCATION

**Prof. A. B. Vawhale**  
Cultural In-charge

**Prof. Y. A. Kale**  
Cultural In-charge

**Prof. M. M. Hanmanth**  
Sports In-charge

**Dr. R. S. Pawar**  
Principal



Shreeyash Pratihthan's  
**Shreeyash College of Engineering  
& Technology, Aurangabad**



Approved by AICTE (New Delhi) & DTE (Mumbai)  
Affiliated to Dr. Babasaheb Ambedkar Technological University, Lonere

# Certificate of Appreciation

This is to certify that

Mr/M<sup>rs</sup>. Ravikant Sanjay Akate of Electrical

Department has participated in Volleyball and secured

First / Second / Participant position, conducted by SYCET, Aurangabad on  
the occasion of Cultural Annual Function **“RISING RHYTHM-2K22”**.

MISSION EDUCATION

**Prof. A. B. Vawhale**  
Cultural In-charge

**Prof. Y. A. Kale**  
Cultural In-charge

**Prof. M. M. Hanmanth**  
Sports In-charge

**Dr. R. S. Pawar**  
Principal



Shreeyash Pratishtan's  
**Shreeyash College of Engineering  
& Technology, Aurangabad**



Approved by AICTE (New Delhi) & DTE (Mumbai)  
Affiliated to Dr. Babasaheb Ambedkar Technological University, Lonere

# Certificate of Appreciation

This is to certify that

Mr/M<sup>ss</sup>. Akash Bhaskar Kakde of Electrical

Department has participated in Volleyball and secured

First / Second / Participant position, conducted by SYCET, Aurangabad on  
the occasion of Cultural Annual Function **“RISING RHYTHM-2K22”**.

MISSION EDUCATION

**Prof. A. B. Vawhale**  
Cultural In-charge

**Prof. Y. A. Kale**  
Cultural In-charge

**Prof. M. M. Hanmanth**  
Sports In-charge

**Dr. R. S. Pawar**  
Principal



Shreeyash Pratishthan's  
**Shreeyash College of Engineering  
& Technology, Aurangabad**



Approved by AICTE (New Delhi) & DTE (Mumbai)  
Affiliated to Dr. Babasaheb Ambedkar Technological University, Lonere

# Certificate of Appreciation

This is to certify that

Mr/M<sup>ss</sup>. Jagdish Ankush Taur of Electrical

Department has participated in Volleyball and secured  
First / Second / Participant position, conducted by SYCET, Aurangabad on  
the occasion of Cultural Annual Function **"RISING RHYTHM-2K22"**.

MISSION EDUCATION

**Prof. A. B. Vawhale**  
Cultural In-charge

**Prof. Y. A. Kale**  
Cultural In-charge

**Prof. M. M. Hanmanth**  
Sports In-charge

**Dr. R. S. Pawar**  
Principal



Shreeyash Pratishthan's  
**Shreeyash College of Engineering  
& Technology, Aurangabad**



Approved by AICTE (New Delhi) & DTE (Mumbai)  
Affiliated to Dr. Babasaheb Ambedkar Technological University, Lonere

# Certificate of Appreciation

This is to certify that

Mr/M<sup>iss</sup>. Sushant Bhagwat Waghmare of Electrical

Department has participated in Volleyball and secured

First / Second / Participant position, conducted by SYCET, Aurangabad on  
the occasion of Cultural Annual Function "**RISING RHYTHM-2K22**".

MISSION EDUCATION

**Prof. A. B. Vawhale**  
Cultural In-charge

**Prof. Y. A. Kale**  
Cultural In-charge

**Prof. M. M. Hanmanth**  
Sports In-charge

**Dr. R. S. Pawar**  
Principal





Shreyash Pratishtan's  
**Shreyash College of Engineering  
& Technology, Aurangabad**

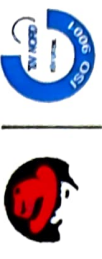

Approved by AICTE (New Delhi) & DTE (Mumbai)  
Affiliated to Dr. Babasaheb Ambedkar Technological University, Lonere

# Certificate of Appreciation

This is to certify that

Mr/Miss. Rushikesh Baban Pathade of Electrical

Department has participated in Volleyball and secured

First / Second / Participant position, conducted by SYCET, Aurangabad on

the occasion of Cultural Annual Function **“RISING RHYTHM-2K22”**.

MISSION EDUCATION

B. V.

**Prof. A. B. Vawhale**

Cultural In-charge

Y. A.

**Prof. Y. A. Kale**

Cultural In-charge

C. M.

**Prof. M. M. Hanmanth**

Sports In-charge

R. S. P.

**Dr. R. S. Pawar**

Principal



Shreeyash Pratihthash's  
**Shreeyash College of Engineering  
& Technology, Aurangabad**



Approved by AICTE (New Delhi) & DTE (Mumbai)  
Affiliated to Dr. Babasaheb Ambedkar Technological University, Lonere

# Certificate of Appreciation

This is to certify that

Mr/M<sup>iss</sup>. Shivraj Vishnu Tangade of Electrical

Department has participated in Volleyball and secured

First / Second / Participant position, conducted by SYCET, Aurangabad on  
the occasion of Cultural Annual Function **“RISING RHYTHM-2K22”**.

MISSION EDUCATION

**Prof. A. B. Vawhale**

Cultural In-charge

**Prof. Y. A. Kale**

Cultural In-charge

**Prof. M. M. Hanmanth**

Sports In-charge

**Dr. R. S. Pawar**

Principal



Shreeyash Pratihthan's  
**Shreeyash College of Engineering  
& Technology, Aurangabad**



Approved by AICTE (New Delhi) & DTE (Mumbai)  
Affiliated to Dr. Babasaheb Ambedkar Technological University, Lonere

# Certificate of Appreciation

This is to certify that

Mr/Miss. Rojesh Mansingh Rathod of Electrical

Department has participated in Volleyball and secured

First / Second / Participant position, conducted by SYCET, Aurangabad on  
the occasion of Cultural Annual Function **“RISING RHYTHM-2K22”**.

MISSION EDUCATION

**Prof. A. B. Vawhale**  
Cultural In-charge

**Prof. Y. A. Kale**  
Cultural In-charge

**Prof. M. M. Hanmanth**  
Sports In-charge

**Dr. R. S. Pawar**  
Principal



Shreeyash Pratishthan's  
**Shreeyash College of Engineering  
& Technology, Aurangabad**



Approved by AICTE (New Delhi) & DTE (Mumbai)  
Affiliated to Dr. Babasaheb Ambedkar Technological University, Lonere

# Certificate of Appreciation

This is to certify that

Mr/Miss. Sudarsban Pujaram Chaudari of Mech

Department has participated in Volleyball and secured

✓ First / Second / Participant position, conducted by SYCET, Aurangabad on

the occasion of Cultural Annual Function **“RISING RHYTHM-2K22”**.

MISSION EDUCATION

**Prof. A. B. Vawhale**

Cultural In-charge

**Prof. Y. A. Kale**

Cultural In-charge

**Prof. M. M. Hanmanth**

Sports In-charge

**Dr. R. S. Pawar**

Principal



Shreeyash Pratishtan's  
**Shreeyash College of Engineering  
& Technology, Aurangabad**



Approved by AICTE (New Delhi) & DTE (Mumbai)  
Affiliated to Dr. Babasaheb Ambedkar Technological University, Lonere

# Certificate of Appreciation

This is to certify that

Mr/M<sup>iss</sup>. Shubham Narayan Gawande of Mech

Department has participated in Volleyball and secured

First / Second / Participant position, conducted by SYCET, Aurangabad on  
the occasion of Cultural Annual Function "**RISING RHYTHM-2K22**".

MISSION EDUCATION

**Prof. A. B. Vawhale**

Cultural In-charge

**Prof. Y. A. Kale**

Cultural In-charge

**Prof. M. M. Hanmanth**

Sports In-charge

**Dr. R. S. Pawar**

Principal



Shreeyash Pratishthan's  
**Shreeyash College of Engineering  
& Technology, Aurangabad**



Approved by AICTE (New Delhi) & DTE (Mumbai)  
Affiliated to Dr. Babasaheb Ambedkar Technological University, Lonere

# Certificate of Appreciation

This is to certify that

Mr/M~~iss~~. Navnath Vishnu Shinde of Mech

Department has participated in Volleyball and secured  
First / Second / Participant position, conducted by SYCET, Aurangabad on  
the occasion of Cultural Annual Function **“RISING RHYTHM-2K22”**.

MISSION EDUCATION

**Prof. A. B. Vawhale**  
Cultural In-charge

**Prof. Y. A. Kale**  
Cultural In-charge

**Prof. M. M. Hanmanth**  
Sports In-charge

**Dr. R. S. Pawar**  
Principal



Shreeyash Pratishtan's  
**Shreeyash College of Engineering  
& Technology, Aurangabad**



Approved by AICTE (New Delhi) & DTE (Mumbai)  
Affiliated to Dr. Babasaheb Ambedkar Technological University, Lonere

# Certificate of Appreciation

This is to certify that

Mr/Miss. Bhagwat Ashok Dhakane of Mech

Department has participated in Volleyball and secured  
✓ First / Second / Participant position, conducted by SYCET, Aurangabad on  
the occasion of Cultural Annual Function **“RISING RHYTHM-2K22”**.

MISSION EDUCATION

**Prof. A. B. Vawhale**  
Cultural In-charge

**Prof. Y. A. Kale**  
Cultural In-charge

**Prof. M. M. Hanmanth**  
Sports In-charge

**Dr. R. S. Pawar**  
Principal



**Shreeyash Pratishtan's**  
**Shreeyash College of Engineering**  
**& Technology, Aurangabad**



Approved by AICTE (New Delhi) & DTE (Mumbai)  
Affiliated to Dr. Babasaheb Ambedkar Technological University, Lonere

# Certificate of Appreciation

This is to certify that

Mr/M<sup>ss</sup>. Musthak Rasul Shaikh of Mech

Department has participated in Volleyball and secured  
First / Second / Participant position, conducted by SYCET, Aurangabad on  
the occasion of Cultural Annual Function "**RIISING RHYTHM-2K22**".

MISSION EDUCATION

**Prof. A. B. Vawhale**  
Cultural In-charge

**Prof. Y. A. Kale**  
Cultural In-charge

**Prof. M. M. Hanmanth**  
Sports In-charge

**Dr. R. S. Pawar**  
Principal





Shreeyash Pratihthan's  
**Shreeyash College of Engineering  
& Technology, Aurangabad**



Approved by AICTE (New Delhi) & DTE (Mumbai)  
Affiliated to Dr. Babasaheb Ambedkar Technological University, Lonere

# Certificate of Appreciation

This is to certify that

Mr/Mi<sup>ss</sup>. Roban Ashok Kulkarni of Mech

Department has participated in Nolleyball and secured

✓ First / Second / Participant position, conducted by SYCET, Aurangabad on  
the occasion of Cultural Annual Function **“RISING RHYTHM-2K22”**.

MISSION EDUCATION

**Prof. A. B. Vawhale**  
Cultural In-charge

**Prof. Y. A. Kale**  
Cultural In-charge

**Prof. M. M. Hanmanth**  
Sports In-charge

**Dr. R. S. Pawar**  
Principal



Shreeyash Pratishthan's  
**Shreeyash College of Engineering  
& Technology, Aurangabad**



Approved by AICTE (New Delhi) & DTE (Mumbai)  
Affiliated to Dr. Babasaheb Ambedkar Technological University, Lonere

# Certificate of Appreciation

This is to certify that

Mr/Miss. Rushikesh - Madan Jadhav of Mech

Department has participated in Volleyball and secured

✓ First / Second / Participant position, conducted by SYCET, Aurangabad on  
the occasion of Cultural Annual Function "**RISING RHYTHM-2K22**".

MISSION EDUCATION

**Prof. A. B. Vawhale**  
Cultural In-charge

**Prof. Y. A. Kale**  
Cultural In-charge

**Prof. M. M. Hanmanth**  
Sports In-charge

**Dr. R. S. Pawar**  
Principal



Shreyash Pratishtan's

# Shreyash College of Engineering & Technology, Aurangabad



Approved by AICTE (New Delhi) & DTE (Mumbai)  
Affiliated to Dr. Babasaheb Ambedkar Technological University, Lonere

## Certificate of Appreciation

This is to certify that

Mr/M<sup>ss</sup>. Pratik Arjun Juye of Mech

Department has participated in Volleyball and secured  
First / Second / Participant position, conducted by SYCET, Aurangabad on  
the occasion of Cultural Annual Function "**RISING RHYTHM-2K22**".

MISSION EDUCATION

**Prof. A. B. Vawhale**

Cultural In-charge

**Prof. Y. A. Kale**

Cultural In-charge

**Prof. M. M. Hanmanth**

Sports In-charge

**Dr. R. S. Pawar**

Principal



# Shreeyash Pratihthan's Shreeyash College of Engineering & Technology, Aurangabad

**NAAC**  
NATIONAL ASSESSMENT AND  
ACCREDITATION COUNCIL



Approved by AICTE (New Delhi) & DTE (Mumbai)  
Affiliated to Dr. Babasaheb Ambedkar Technological University, Lonere

## Certificate of Appreciation

This is to certify that

Mr/M~~iss~~. Nikhil Ravindra Kulkarni of Mech

Department has participated in Volleyball and secured

First / Second / Participant position, conducted by SYCET, Aurangabad on  
the occasion of Cultural Annual Function **“RISING RHYTHM-2K22”**.

MISSION EDUCATION

  
**Prof. A. B. Vawhale**  
Cultural In-charge

  
**Prof. Y.A. Kale**  
Cultural In-charge

  
**Prof. M. M. Hanmanth**  
Sports In-charge

  
**Dr. R. S. Pawar**  
Principal



Shreeyash Pratishthan's  
**Shreeyash College of Engineering  
& Technology, Aurangabad**



Approved by AICTE (New Delhi) & DTE (Mumbai)  
Affiliated to Dr. Babasaheb Ambedkar Technological University, Lonere

# Certificate of Appreciation

This is to certify that

Mr/Miss. Aniket Madan Jadhav of Mech

Department has participated in Volleyball and secured  
First / Second / Participant position, conducted by SYCET, Aurangabad on  
the occasion of Cultural Annual Function **“RISING RHYTHM-2K22”**.

MISSION EDUCATION

**Prof. A. B. Vawhale**  
Cultural In-charge

**Prof. Y. A. Kale**  
Cultural In-charge

**Prof. M. M. Hanmanth**  
Sports In-charge

**Dr. R. S. Pawar**  
Principal